



Code Compliance Research Report

CCRR-0129

Subject to Renewal: 01/14/2011
Visit www.archtest.com for current status

Issued: 01/14/2010
Page 1 of 11

TimberTech® Limited
894 Prairie Avenue
Wilmington, Ohio 45177
(866) 862-7832

www.timbertech.com

1.0 Subject

Guardrail Systems

BuilderRail® composite guardrail system

2.0 Research Scope

2.1. Building codes

- 2009 International Building Code (IBC)
- 2009 International Residential Code (IRC)

2.2. Properties

- Structural Performance
- Durability
- Surface Burning
- Decay Resistance
- Termite Resistance

3.0 Description

3.1. General – The TimberTech® *BuilderRail®* are guards and guardrails under the definitions of the referenced codes. They are intended for use at or near the open sides of elevated walking areas of buildings and walkways as required by the referenced codes.

3.2. Guard systems include a top and bottom rail (*BuilderBoards®*), baluster connectors, vertical balusters, post sleeves, rail-to-post brackets, foot blocks, decorative moldings and a top cap rail.

3.3. All rails (top, bottom and cap), foot blocks, decorative moldings and post sleeves are extrusions of a common composite material comprised primarily of high density polyethylene (HDPE) and wood flour produced in three colors: Cedar, Grey and Redwood.

3.4. Top cap rails are TimberTech® composite deck boards recognized and listed in Architectural Testing Code Compliance Research Report, CCRR-0128. Top cap rails shall be limited to those with a solid rectangular cross-section with nominal dimensions from 5.43" x 1" to 5.5" x 1.25". See Figure 8.

3.5. The top *BuilderRail®* assembly consists of one *BuilderBoard®*, and is attached to each post with a single post bracket of 0.1" thick, G90 galvanized steel with a powder coat finish using two (2) #8 x 2-1/2" pan-head screws. See Figure 5, 6 and 10.

3.6. The bottom *BuilderRail®* assembly consists of one *BuilderBoard®*, and is attached to each post with a single post bracket of 0.1" thick, G90 galvanized steel with a powder coat finish using two (2) #8 x 2-1/2" pan-head screws. See Figure 5, 6 and 10.

3.7. Metal balusters are 0.75" in diameter and are made from 20 gauge, G90 galvanized steel with a powder coat finish. See Figure 2. A molded nylon connector approximately 0.67" long (1.12" for stair rails), and containing a small hole on its center, is installed using the predrilled holes, onto the top and bottom rails (*BuilderBoards®*) at each baluster position using one (1) each #10 x 1-1/2" flat head screw. The balusters are placed over these connectors at each end to provide a means for securing the balusters to the top and bottom *BuilderBoards®*. See Figures 3 and 4 for sectional profile. See Figure 9 and 10 for assembly details.

3.8. Level guards with heights of 36" and/or 42" above the floor surface are provided in rail lengths up to 91.75". This provides 8 ft (96") from post center to post center. See Table 1.

3.9. Stair guards are provided in rail lengths up to 91.75" as measured along the upper rail. See Table 1.

4.0 Performance Characteristics

4.1. The *BuilderRail®* guard systems described in this report have demonstrated the capacity to resist the design loadings specified in Chapter 16 of the IBC, Section R301 of IRC when tested in accordance with ICC-ES AC174.

4.2. Structural performance has been demonstrated for a temperature range from -20°F to 125°F.

4.3. Materials used are deemed equivalent to preservative treated or naturally durable wood for resistance to weathering effects, decay, and attack from termites.

4.4. The composite material has a flame spread index of 75 when tested according to ASTM E 84. The referenced criteria within AC174, requires a flame spread index not exceeding 200 when tested in accordance with ASTM E 84.

5.0 Installation

Installation shall be in accordance with the manufacturer's installation instructions and this report. Where differences occur between this report and the manufacturer's installation instructions, this report shall govern.

5.1. The top and bottom *BuilderBoard*[®] assemblies, both level and stair, are attached to conventional 4x4 wood posts sleeved with a 4.25" by 4.25" composite post cover with a metal mounting bracket. See Figures 5, 6 and 7.

5.2. The upper bracket attaches to each end of the upper *BuilderBoard*[®] utilizing three (3) #8 x 3/4" pan-head screws. The brackets are attached to the post utilizing two (2) #8 x 3" pan-head screws. See Table 2, Figures 9, 10 and 11.

5.3. The lower bracket attaches to each end of the lower *BuilderBoard*[®] utilizing three (3) #8 x 3/4" pan head screws. The brackets are attached to the post utilizing two (2) #8 x 3" pan head screws. See Table 2, Figures 9, 10 and 11.

5.4. Baluster connectors are installed along the lengths of the upper and lower *BuilderBoard*[®] utilizing baluster connectors (two per baluster) and are secured with one (1) each #10 x 1-1/2" flat-head screw inserted through pre-drilled holes.

5.5. The top cap rail shall be installed over the length of the *BuilderRail*[®] and post system and secured using #8 x 2-1/2" flat-head screws. Screws are positioned 3/4" from the ends and 1-1/2" from the edges of the top cap rail. The top cap rail is also secured to the top *BuilderBoard*[®] every two feet using one (1) #8 x 2-1/2" flat-head screws. See Figure 12.

5.6. Foot blocks are a section of 1.35" square extruded composite picket approximately 3-1/2" long. Foot blocks shall be installed at mid-span of the bottom *BuilderBoard*[®] between the deck surface and the *BuilderBoard*[®] using one (1) #8 x 3-1/2"

5.7. The wood in the supporting structure including support posts shall have a specific gravity of 0.50 or greater (Southern Yellow Pine or better) and a minimum thickness to allow full penetration of the bracket mounting screws.

6.0 Supporting Evidence

6.1. Drawings and installation instructions submitted by the manufacturer.

6.2. The reports of testing and engineering analysis demonstrating compliance with the performance requirements of ICC-ES Acceptance Criteria for Deck Board Span Ratings and Guardrail Systems (Guards and Handrails), AC174 effective June 1, 2009.

6.3. The reports of testing and engineering analysis demonstrating compliance with the performance requirements ASTM D 7032-07, Standard Specification for Establishing Performance Ratings for Wood-Plastic Composite Deck Boards and Guardrail Systems (Guards or Handrails)..

6.4. A quality control manual that is in accordance with the ICC-ES AC10, "Acceptance Criteria for Quality Documentation", effective March 1, 2009.

7.0 Conditions of Use

The guard assemblies identified in this report are deemed to comply with the intent of the provisions of the referenced building codes subject to the following conditions.

7.1. Guards are installed in accordance with manufacturer's published installation instructions and this report. Where the manufacturer's instructions differ from this report this report shall govern.

7.2. Conventional wood supports including support posts for guards are not within the scope of this report and are subject to evaluation and approval by the building official. Supports must satisfy the design load requirements specified in Chapter 16 of the IBC and must provide suitable material for anchorage of the rail brackets. Where required by the building official, engineering calculations and details prepared by a licensed design professional shall be provided.

7.3. Compatibility of fasteners, and other metallic components with the supporting structure, including chemically treated wood, is not within the scope of this report

7.4. TimberTech[®] Limited Guard Systems are manufactured in Wilmington and Columbus, Ohio in accordance with the manufacturer's approved quality control system with inspections by Architectural Testing, Inc. (AA-676.)

8.0 Identification

The composite guard assemblies produced by TimberTech[®] Limited identified in this report, shall be identified with labeling on the individual components or the packaging and include the following;

8.1. name and/or trademark of the manufacturer and the manufacturers address

8.2. the identifying mark of the independent inspection agency, (AA-676)

8.3. the ATI Code Compliance Research Report Number (CCRR-0129) except top rail cap member

Deck boards used for top cap rail are identified by ATI Code Compliance Research Report Number, CCRR-0128

9.0 Code Compliance Research Report Use

9.1. Approval of building products and/or materials can only be granted by a building official having legal authority in the specific jurisdiction where approval is sought.

9.2. Code Compliance Research Reports shall not be used in any manner that implies an endorsement of the product by ATI.

9.3. Reference to the Architectural Testing internet web site address at www.archtest.com is recommended to ascertain the current version and status of this report.

Table 1
Railing System Building Code Recognition

TimberTech [®] Guard System	Type of System	Guard System Size (Length x Height) and Building Code Recognition	
		IBC	IRC ³
BuilderRail[®] Level and Stair	Level Systems ⁽¹⁾	91.75" x 42"	91.75"x 36"
	Stair Systems ⁽²⁾	91.75"x42"	91.75"x34"

¹ Level Railing lengths are maximum clear length between supports. Railing height is the minimum installed height from walking surface to top of top rail.

² Stair Railing lengths are maximum clear length between supports. Stair Heights indicate minimum allowed height as measured vertically from the leading edge of the stair nose

³ Limited to use in One- and Two-Family Dwellings (IRC).

**Table 2
Rail/Bracket Fastening Schedule**

Guard System	Bracket to <i>BuilderBoards</i>®	Foot Blocks to <i>BuilderBoards</i>®	Bracket to Post
<i>BuilderRail</i> ® <i>Composite Guardrail Systems</i> Level and Stair	One (1) metal bracket is attached to each end of the upper and lower <i>BuilderBoard</i> ® using three (3) #8 x 3/4" long pan-head screws	One (1) #8 x 3-1/2" pan-head screw	<u><i>BuilderBoard</i>® to Posts:</u> Two (2) #8 x 3" long coated panhead screws.

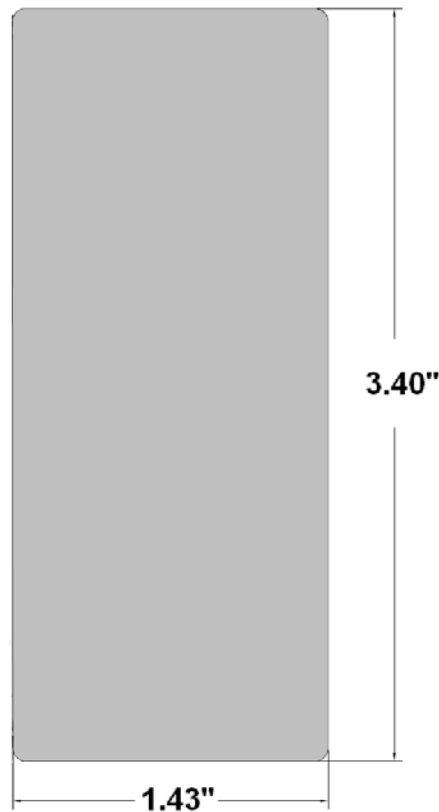

**Figure 1
BuilderBoard® - Profile**

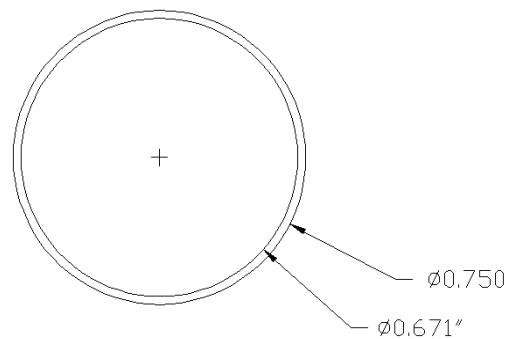

Figure 2
Builder Rail® - Baluster Profile

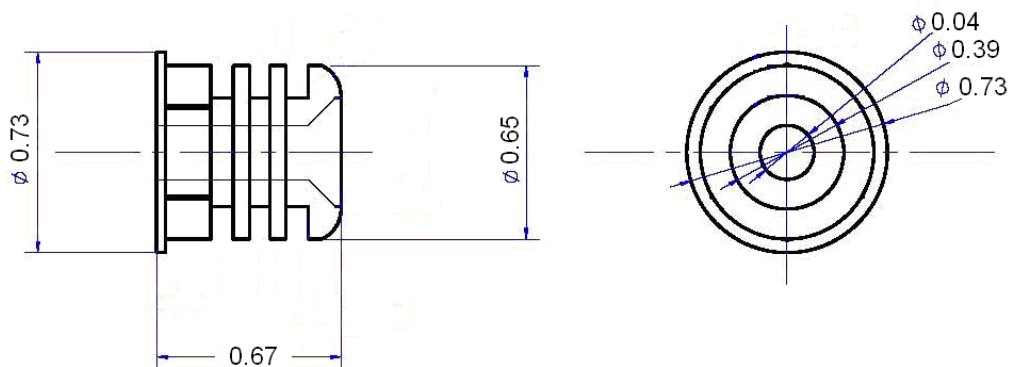

Figure 3
Builder Rail® - Baluster Connector, Level Assembly

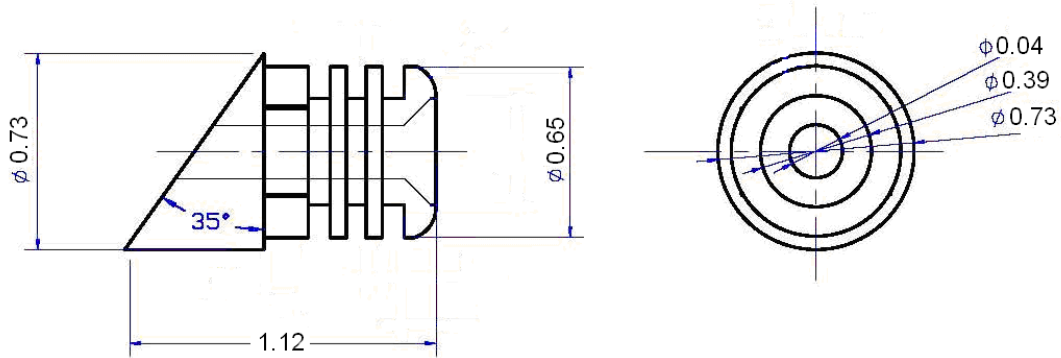

Figure 4
Builder Rail® - Baluster Connector, Stair Assembly

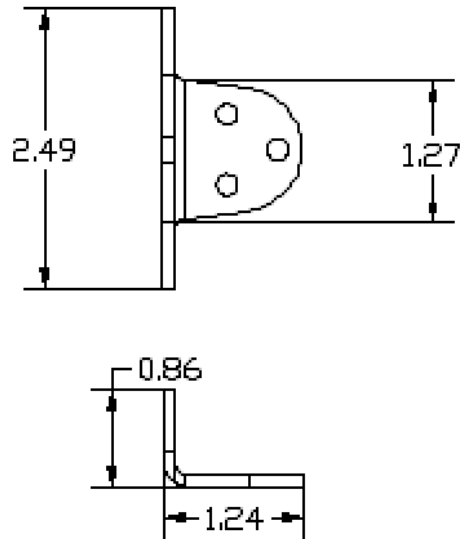

Figure 5
Builder Rail® - Rail Bracket

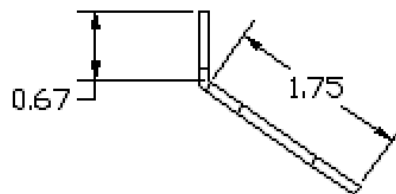
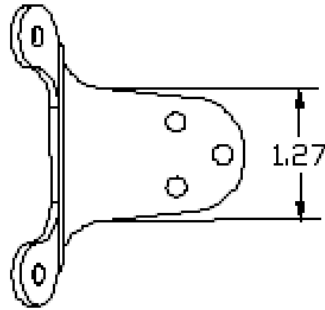

Figure 6
Builder Rail® - Stair Rail Bracket

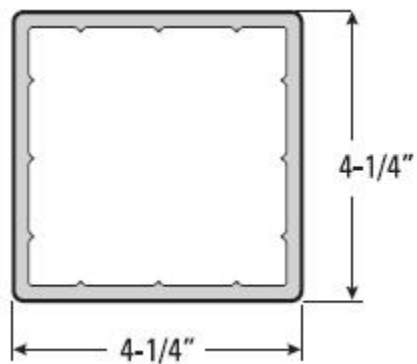
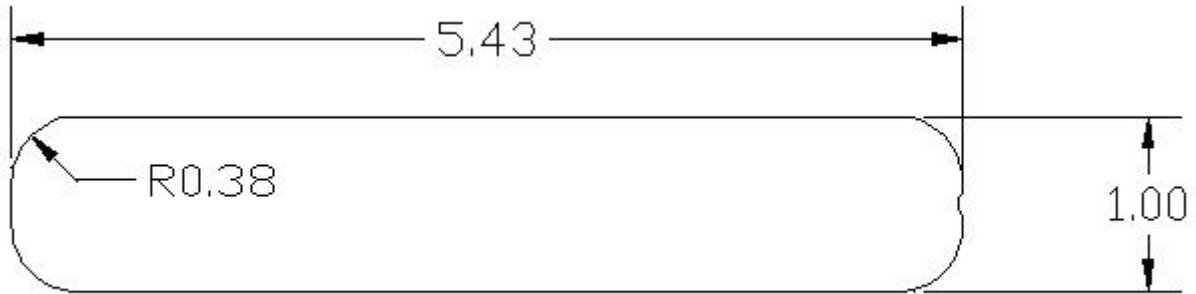
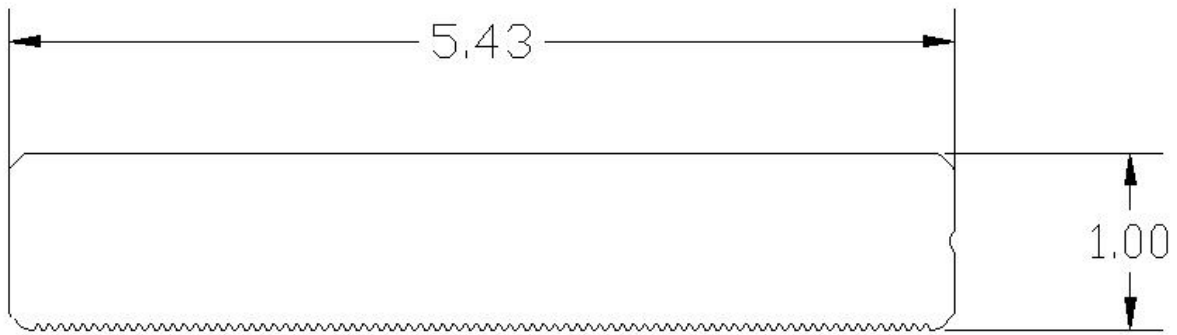

Figure 7
BuilderRail® - Post Sleeve Profiles



5/4 and TwinFinish Deck Board



Earthwood Deck Board

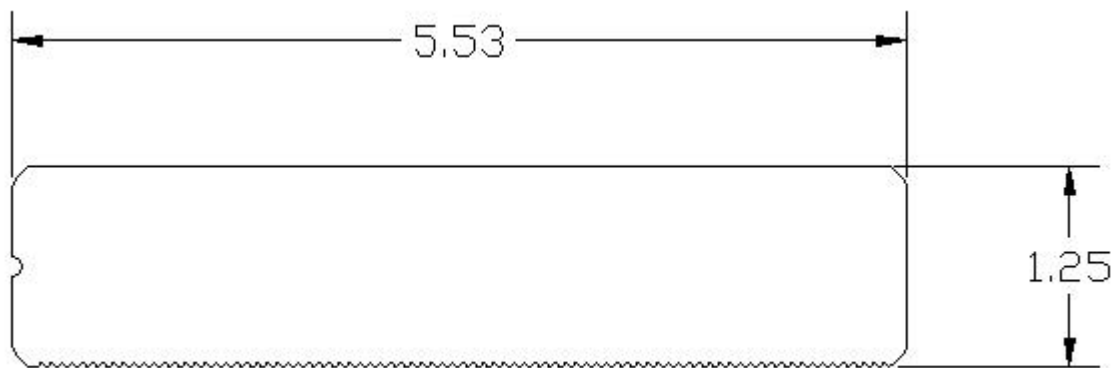

DockSider

Figure 8
BuilderRail® - Cap Rail Profiles

(Ref. CCRR-0128)

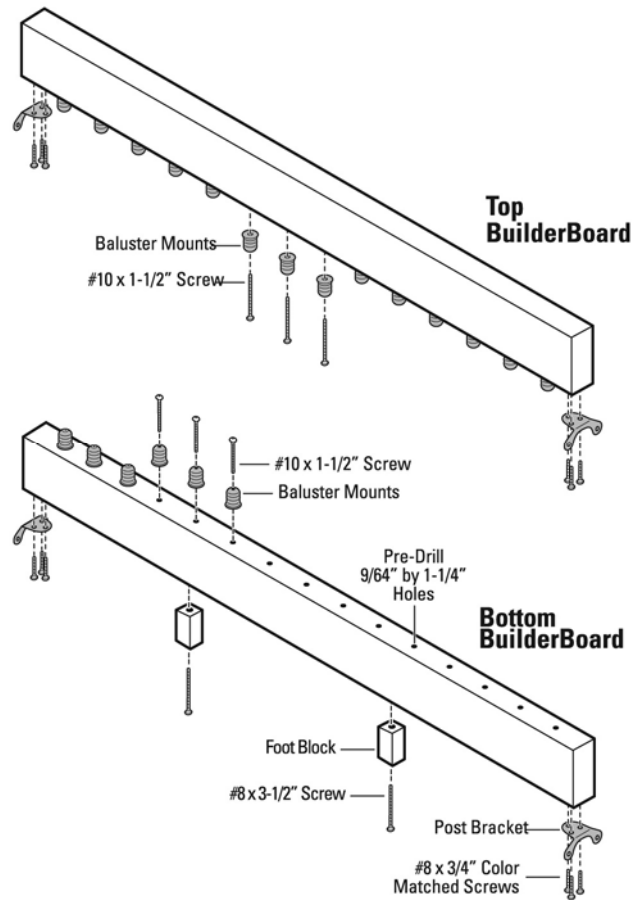

Figure 9
BuilderRail® - Attachment Bracket and Support Block

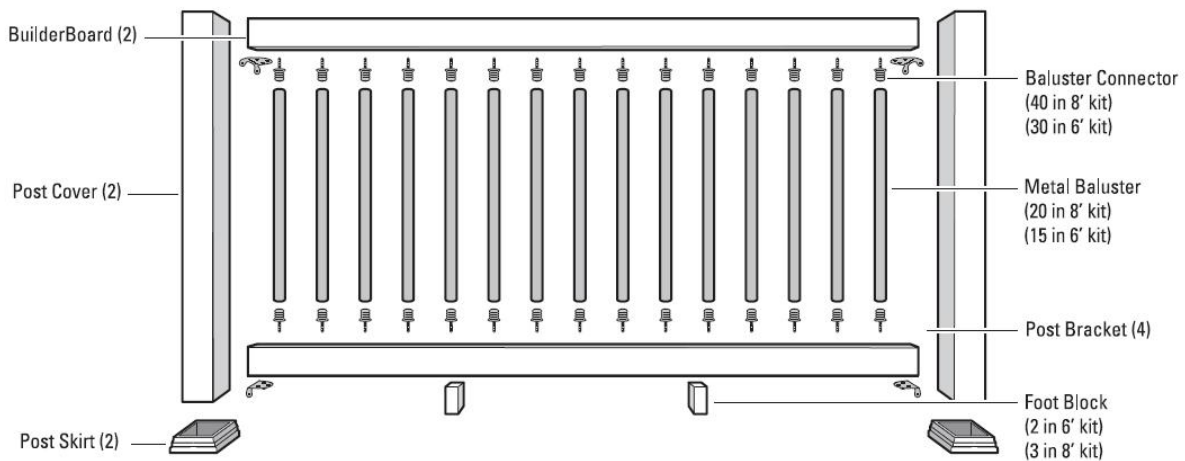

Figure 10
BuilderRail® - Typical Level Assembly

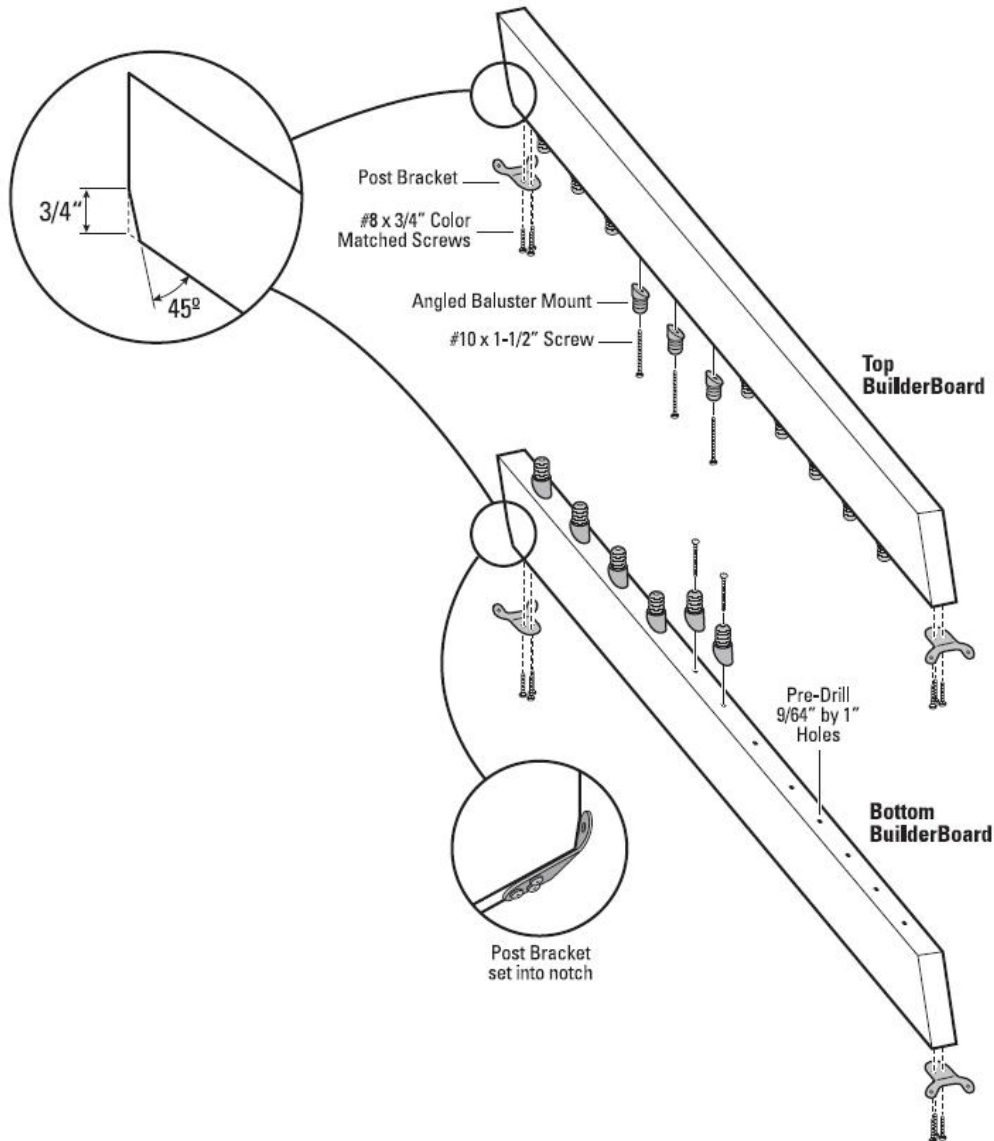

Figure 11
BuilderRail® – Typical Stair Assembly

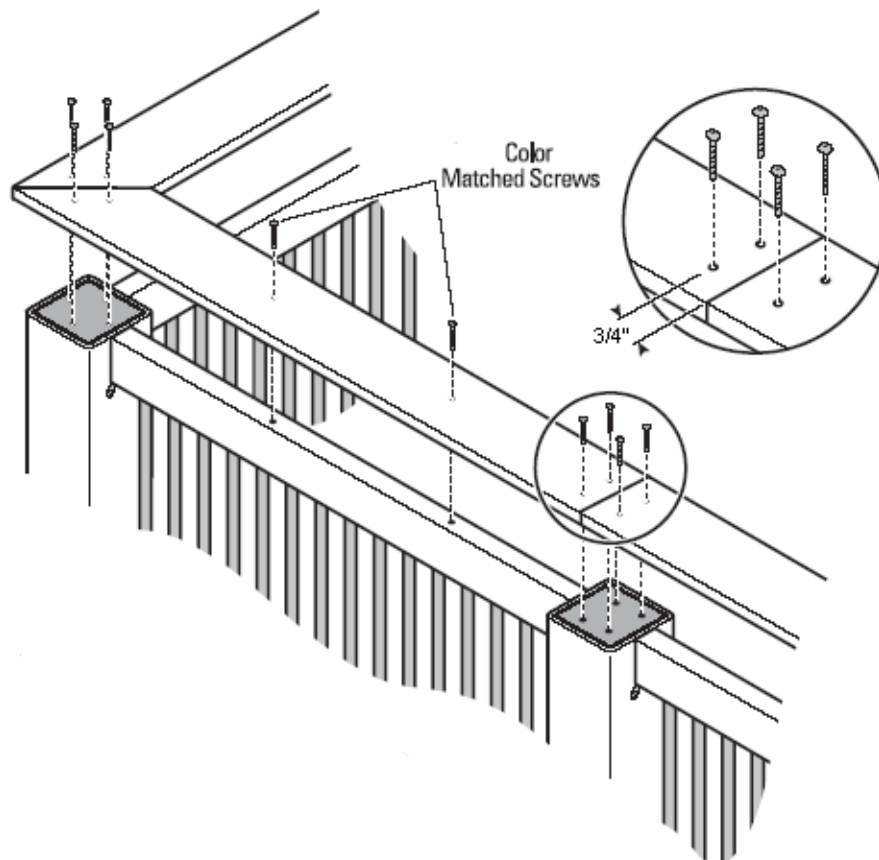

Figure 12
BuilderRail® - Top Cap Rail Assembly