

ICC-ES Evaluation Report

ESR-1400

Reissued October 1, 2010

This report is subject to re-examination in one year.

www.icc-es.org | (800) 423-6587 | (562) 699-0543

A Subsidiary of the International Code Council®

**DIVISION: 06 00 00—WOOD, PLASTICS, AND
COMPOSITES**
Section: 06 50 00—Structural Plastics
Section: 06 63 00—Plastic Railings
REPORT HOLDER:
TIMBERTECH® LIMITED
 894 PRAIRIE AVENUE
 WILMINGTON, OHIO 45177
 (866) 862-7832
www.timbertech.com
EVALUATION SUBJECT:
TIMBERTECH® ORNAMENTAL RAILING SYSTEM
1.0 EVALUATION SCOPE
Compliance with the following codes:

- 2009 *International Building Code*® (2009 IBC)
- 2009 *International Residential Code*® (2009 IRC)
- 2006 *International Building Code*® (2006 IBC)
- 2006 *International Residential Code*® (2006 IRC)

Properties evaluated:

- Structural
- Durability
- Surface-burning characteristics

2.0 USES

The TimberTech® Ornamental Railing System evaluated in this report is limited to exterior use as a guard for balconies, porches, stairs and decks of one- and two-family residential Type V-B construction (IBC) and structures constructed in accordance with the IRC.

3.0 DESCRIPTION
3.1 General:

The TimberTech® Ornamental Railing System is a wood thermoplastic composite lumber (WTCL) product consisting of wood flour and high-density polyethylene (HDPE), with percentages as described in the quality control manual. The TimberTech® Ornamental Railing System is manufactured by an extrusion process in three colors: cedar, grey, and redwood.

3.2 Guards:

3.2.1 General: The TimberTech® Ornamental Railing System is installed with a height of 36 inches (914 mm) or 42 inches (1067 mm) above the walking surface. The top and bottom rails are comprised of a structural 2¹/₂-inch-by-2¹/₂-inch (64 by 64 mm) universal structural core. The top rail has a second 2³/₄-inch-by-2³/₈-inch (70 by 60 mm) “bread loaf” shaped ornamental attachment affixed atop the universal structural core. The baluster is a 1³/₈-inch-square (35 mm) solid spindle. See Figure 1 for typical component cross sections.

3.2.2 Durability: When subjected to weathering, insect attack, and other decaying elements, material used to manufacture the TimberTech® Ornamental Railing System is equivalent in durability to preservative-treated or naturally durable lumber when used in locations described in Section 2.0. The TimberTech® Ornamental Railing System has been evaluated for structural performance when exposed to a temperature range from -20°F (-29°C) to 125°F (52°C).

3.2.3 Surface-burning Characteristics: When tested in accordance with ASTM E 84, the TimberTech® Ornamental Railing System has a flame-spread index of no greater than 200.

4.0 DESIGN AND INSTALLATION
4.1 General:

Installation of the TimberTech® Ornamental Railing System must comply with this report and the manufacturer’s published installation instructions. The manufacturer’s published installation instructions must be available at the jobsite at all times during installation. When the manufacturer’s published installation instructions differ from this report, this report must govern.

4.2 Guards:

4.2.1 Structural: The TimberTech® Ornamental Railing System will resist the code-specified loads when installed at a maximum length as prescribed in Table 1 of this report and when the guard is supported on both ends by the supporting construction. See Figure 2 for a typical rail assembly.

4.2.2 Installation: The top and bottom universal rails of the TimberTech® Ornamental Railing System must be attached to each end of each baluster utilizing one No. 8 by 3¹/₂-inch-long (89 mm) corrosion-resistant screw. Balusters must be spaced a maximum of 5 inches

(127 mm) on center. The ornamental “bread loaf” top rail attachment must be fastened to the universal structural core with one No. 8 by 3¹/₂-inch pan-head stainless steel or corrosion-resistant screw at every fourth baluster. The universal structural rails must be supported by the connection to the last baluster installed adjacent to the supporting construction and to the supporting construction with two No. 10 by 3¹/₂-inch flathead screws at the top rail and one No. 10 by 3¹/₂-inch flathead screw at the bottom rail on each rail end, as illustrated in the manufacturer’s published installation instructions. The baluster must be attached to the supporting construction with three No. 8 by 3¹/₂-inch screws as shown in the manufacturer’s published installation instructions. The supporting construction must have a minimum specific gravity of 0.55. See Section 5.5 of this report for additional information regarding this issue. Support blocks must be installed, as shown in the manufacturer’s published installation instruction, at a maximum spacing of 24 inches (610 mm) on center and must be fastened to the bottom of the universal rail with one No. 8 by 3¹/₂-inch pan-head screw.

5.0 CONDITIONS OF USE

The TimberTech® Ornamental Railing System described in this report complies with, or is a suitable alternative to what is specified in, those codes listed in Section 1.0 of this report, subject to the following conditions:

- 5.1 The use of the TimberTech® Ornamental Railing System must be limited to exterior use as a guard system for balconies, porches, stairs and decks of one- and two-family residential Type V-B construction (IBC) and structures constructed in accordance with the IRC.
- 5.2 Installation must comply with this report, the manufacturer’s published installation instructions and the applicable code. Only those fasteners and fastener configurations described in this report have been evaluated for the installation of the TimberTech® Ornamental Railing System. When the manufacturer’s published installation instructions differ from this report, this report must govern.
- 5.3 The compatibility of the fasteners and other metal hardware with the supporting construction, including chemically treated wood, is subject to approval by the code official.
- 5.4 Adjustment factors outlined in the AFPA *National Design Specification* and applicable codes must not apply to the allowable capacity and maximum spans for the TimberTech® Ornamental Railing System.

5.5 The TimberTech® Ornamental Railing System has not been evaluated with a post installed in the system. The determination of the ability of the supporting construction to resist the code-specified loads is outside the scope of this report.

5.6 The TimberTech® Ornamental Railing System must be fastened directly to supporting construction. Where required by the code official, engineering calculations and construction documents consistent with this report must be submitted for approval. The calculations must verify that the supporting construction complies with the applicable building code requirements and is adequate to resist the loads imparted upon it from the products and systems discussed in this report. The documents must contain details of the attachment to the supporting structure consistent with the requirements of this report. The documents must be prepared by a registered design professional where required by the statutes of the jurisdiction in which the project is to be constructed.

5.7 The top rail of the TimberTech® Ornamental Railing System must not be permitted to be used as a handrail for stairways or ramps.

5.8 The TimberTech® Ornamental Railing System is produced in Wilmington, Ohio, under a quality control program with inspections by Architectural Testing, Inc. (AA-676).

6.0 EVIDENCE SUBMITTED

Data establishing compliance of the guard system with the ICC-ES Acceptance Criteria for Deck Board Span Ratings and Guardrail Systems (Guards and Handrails) (AC174), dated July 2010.

7.0 IDENTIFICATION

The TimberTech® Ornamental Railing System described in this report is identified on each individual piece or the packaging by a stamp bearing the manufacturer’s name (TimberTech® Limited) and/or trademark, the product name, the name of the inspection agency (Architectural Testing, Inc.), the allowable span and the evaluation report number (ESR-1400). Additionally, the railing system packaging must be labeled “For Use in One- and Two-Family Dwellings Only.”

TABLE 1—MAXIMUM GUARDRAIL SPAN^{2,3}

PRODUCT NAME	APPLICABLE BUILDING CODE ⁴		MAXIMUM SPAN (inches) ¹
	IBC	IRC	
TimberTech [®] Ornamental Railing ⁵ , 36 inches high	Yes ⁶	Yes	91.75
TimberTech [®] Ornamental Railing ⁵ , 42 inches high	Yes	Yes	91.75

For SI: 1 inch = 25.4 mm.

¹Maximum span must be measured from edge-of-supporting-construction to edge-of-supporting-construction.

²Maximum allowable span has been adjusted for durability. No further increases are permitted.

³Evaluation of this guardrail does not include the post, post sleeve or post base attachment. The ability of the supporting construction to resist the reactionary loads must be established as required by the code official.

⁴Indicates compliance with the respective building codes.

⁵Evaluation is limited to one- and two-family residential structures.

⁶The 36-inch guard is limited to the open side of exterior stairs for occupancies in Group R-3 containing no more than two dwelling units.

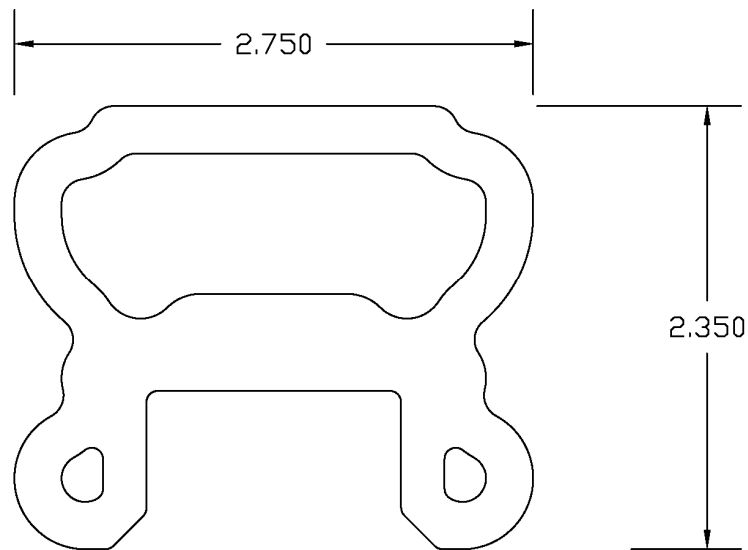

ORNAMENTAL TOP RAIL

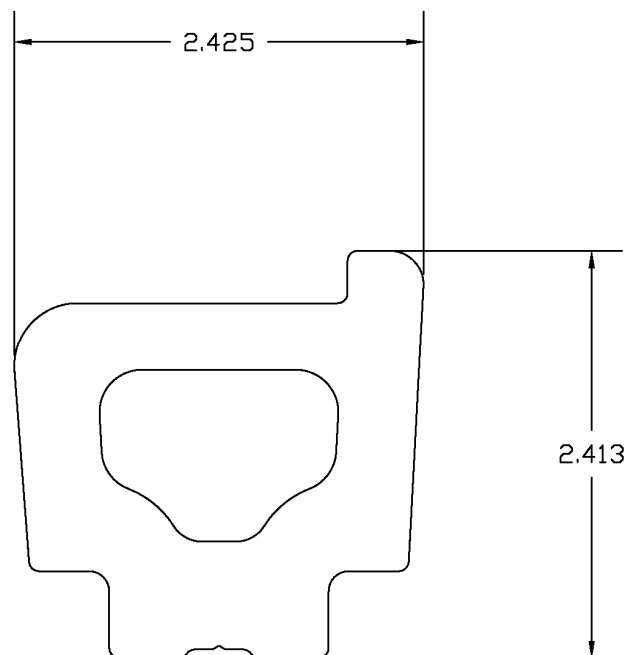

UNIVERSAL RAIL

(Orientation is as installed in bottom rail)

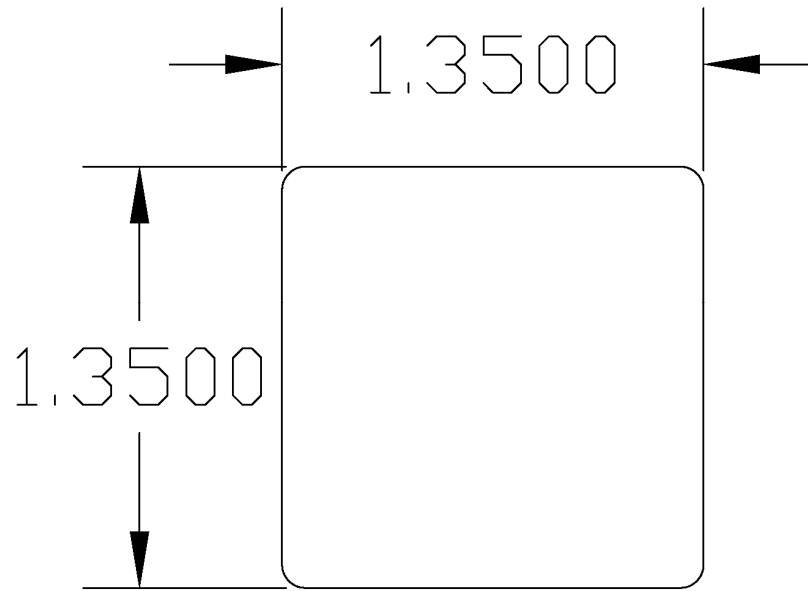

BALUSTER

For SI: 1 inch = 25.4 mm.

FIGURE 1—GUARDRAIL COMPONENT PROFILES

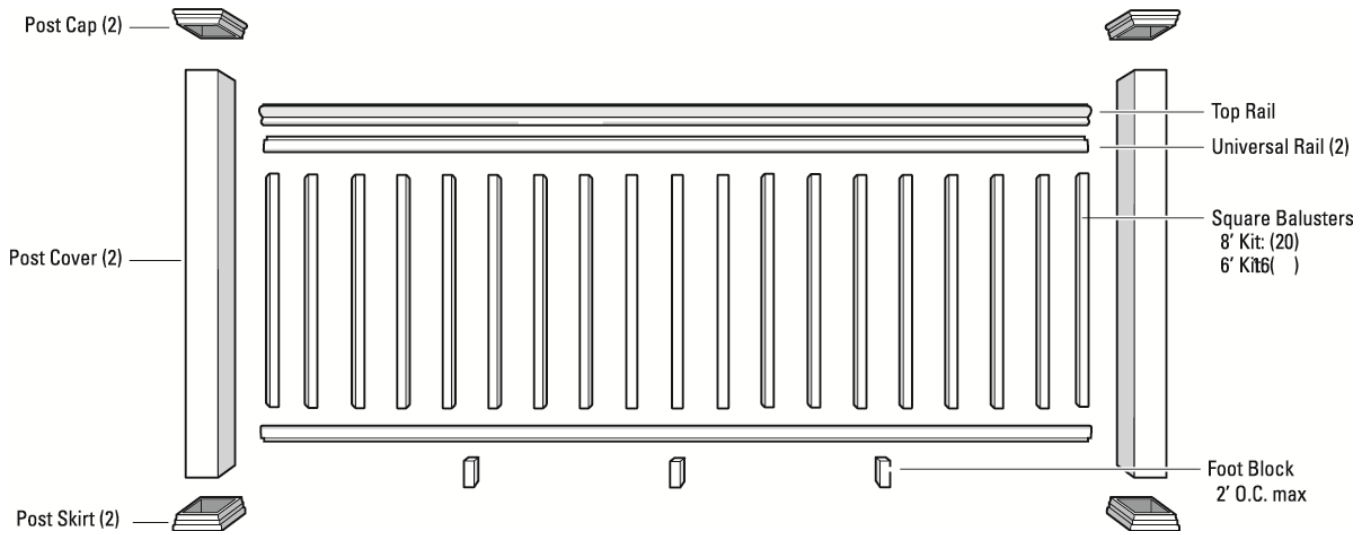

For SI: 1 inch = 25.4 mm.

(Note: the post is outside the scope of this evaluation report)

FIGURE 2—TIMBERTECH® ORNAMENTAL GUARDRAIL SYSTEM