



Code Compliance Research Report

CCRR-0196

Subject to Renewal: 05/16/2018
Visit www.ati-es.com for current status

Issued: 05/24/2017
Page 1 of 9

CPG Building Products LLC
(dba AZEK Building Products)
894 Prairie Avenue
Wilmington, Ohio 45177
(866) 862-7832
www.cpgbp.com

1.0 Subject

Evolutions Rail™ Contemporary

Evolutions Rail™ Builder

2.0 Research Scope

2.1 Building Codes:

2015 International Building Code (IBC)
2015 International Residential Code (IRC)

2012 International Building Code (IBC)
2012 International Residential Code (IRC)

2.2 Properties:

Structural Performance
Durability
Surface Burning

3.0 Description

3.1 General – The *Evolutions Rail™* systems are guardrails or guards under the definitions of the referenced codes intended for exterior use on elevated walking areas in buildings and walkways as required by the codes.

3.2 Guard Assemblies – *Evolutions Rail™* systems are provided as level guards for level walking areas such as decks, balconies and porches, and sloped guards for open sides of stairways.

3.2.1 *Evolutions Rail™* level and stair railing systems are provided with rail lengths up to 91 inches in length (measured between the inside of supports) and an installed height of 42 inches. See Table 2 for qualified lengths and configurations.

3.3 Materials and Processes – The *Evolutions Rail™* systems are an assemblage of co-extruded wood-plastic composite (WPC) material with a polymer capstock manufactured in three colors: Brick, Classic Black, and Traditional Walnut.

3.4 The rail systems are provided in two series, the *Contemporary* and *Builder*. See Table 1 for a description of each railing series.

4.0 Performance Characteristics

4.1 The *Evolutions Rail™* systems described in this report have demonstrated the capacity to resist the design loads specified in Chapter 16 of the IBC and Section R301 of the IRC when tested in accordance with ICC-ES AC174 and ASTM D 7032.

4.2 Structural performance has been demonstrated for a temperature range from -20°F to 125°F.

4.3 Materials used to produce the *Evolutions Rail™* systems are deemed equivalent to preservative treated or naturally durable wood for resistance to weathering effects, decay, and attack from termites.

4.4 Materials used have a flame spread index less than 200 when tested in accordance with ASTM E 84.

5.0 Installation

Installation shall be in accordance with the manufacturer's installation instructions and this report. Where differences occur between this report and the manufacturer's installation instructions, this report shall govern.

5.1 The top and bottom rails are attached to structural supports utilizing stainless steel mounting brackets. See Figure 1 through Figure 4. Stainless steel brackets are secured to structural wood supports (posts or framing) with #10 x 1.5 inch stainless steel screws and to the rails with #10 x 1 inch self-drilling stainless steel screws. Fastening schedules are described in Table 3.

5.2 *Evolutions Rail™* systems are attached to and supported by structural wood posts or other framing. Non-structural 5 inch square WPC post sleeves can be installed over a conventional 4x4 wood post. Code compliance assessment of conventional wood posts is not within the scope of this report.

5.3 The wood in the supporting structure, including support posts, shall have a specific gravity of 0.50 or greater (Southern Yellow Pine or better) and a minimum thickness to allow full engagement of the bracket mounting screws.

6.0 Supporting Evidence

6.1 Manufacturer's drawings and installation instructions.

6.2 Reports of testing demonstrating compliance with ICC-ES AC174, Acceptance Criteria for Deck Board Span Ratings and Guardrail Systems (Guards and Handrails), revised February 2014.

6.3 Reports of testing and engineering analysis demonstrating compliance with the performance requirements of ASTM D 7032-08, Standard Specification for Establishing Performance Ratings for Wood-Plastic Composite Deck Boards and Guardrail Systems (Guards or Handrails).

6.4 Documentation of an Intertek approved quality control system for the manufacturing of products recognized in this report.

7.0 Conditions of Use

The guardrail assemblies identified in this report are deemed to comply with the intent of the provisions of the referenced building codes subject to the following conditions:

7.1 Guardrail systems recognized in this report may be used in One- and Two-Family Dwellings regulated by the IRC and all construction types regulated by the IBC in accordance with IBC Section 1406.3, Exception 2. Guardrails less than 42 inches high are limited to use in One- and Two-Family Dwellings (IRC). See Table 2 for additional restrictions based upon Use and Occupancy classification

7.2 Conventional wood guardrail supports including 4x4 posts, and framing are not within the scope of this report and are subject to evaluation and approval by the building official. Supports must satisfy the design load requirements specified in Chapter 16 of the IBC. Supports and framing must provide suitable material for anchorage of the rail brackets and post mount, respectively. Where required by the building official, engineering calculations and details shall be provided.

7.3 Compatibility of fasteners and other metallic components with the supporting structure including chemically treated wood is not within the scope of this report.

7.4 Only those types of fasteners and fastening methods described in this report have been evaluated for the installation of the *Evolutions Rail™* systems; other methods of attachment are outside the scope of this report.

7.5 *Evolutions Rail™* WPC components recognized in this report have not been evaluated for use in areas subject to Formosan termite attack

7.6 TimberTech Limited's *Evolutions Rail™* systems are manufactured in Wilmington, Ohio in accordance with the manufacturer's approved quality control system with inspections by Architectural Testing (IAS AA-676).

8.0 Identification

TimberTech Limited's *Evolutions Rail™* system produced in accordance with this report shall be identified with labeling on the individual components or the packaging that includes the following information:

8.1 The following statement: "ASTM D 7032 compliant. See CCRR-0196 at www.ati-es.com for uses and performance levels";

8.2 The Architectural Testing Code Compliance Research Report mark and number (CCRR-0196).

9.0 Code Compliance Research Report Use

9.1 Approval of building products and/or materials can only be granted by a building official having legal authority in the specific jurisdiction where approval is sought.

9.2 Code Compliance Research Reports shall not be used in any manner that implies an endorsement of the product by Architectural Testing.

9.3 Reference to the Architectural Testing internet web site address at www.ati-es.com is recommended to ascertain the current version and status of this report.

**Table 1 – Railing System Descriptions**

Component	<i>Evolutions Rail™ Contemporary</i> (Figure 1, Figure 2 & Figure 3)	<i>Evolutions Rail™ Builder</i> (Figure 4)
Top Rail	2-1/4" wide by 1-1/4" high co-extruded WPC with top rail cap	1-7/16" wide by 3-5/16" high co-extruded WPC rectangular rail with top rail cap
Top Rail Cap	<i>Evolutions Rail™ Contemporary</i> Top Rail Cap XLM® solid plank ⁽¹⁾ TwinFinish® plank ⁽¹⁾ Earthwood® <i>Evolutions™</i> plank ⁽¹⁾	<i>Evolutions Rail™ Contemporary</i> Top Rail Cap XLM® solid plank ⁽¹⁾ TwinFinish® plank ⁽¹⁾ Earthwood® <i>Evolutions™</i> plank ⁽¹⁾
Bottom Rail	2-1/4" wide by 1-1/4" high co-extruded WPC	1-7/16" wide by 3-5/16" high co-extruded WPC rectangular rail
Rail Bracket	Stainless steel hinge brackets	Stainless steel hinge brackets
Infill	1.25" sq., co-extruded WPC baluster <i>Feeney® CableRail™</i> with <i>Quick-Connect®</i> fittings, and 3/4" sq. aluminum intermediate balusters 0.75" diameter, round, aluminum baluster	0.75" diameter, round, aluminum baluster
Foot Block	1-1/4" square, solid, co-extruded expanded cellular WPC picket	
Post Sleeve	5" sq., 0.250" thick wall, co-extruded wood-plastic composite profile with twelve internal ribs	

⁽¹⁾ TimberTech® solid deck board recognized and listed in Architectural Testing Code Compliance Research Report, CCRR-0128. Grooved deck boards shall not be used for top rail caps.

Table 2 – Guardrail Systems: IBC (All Use Groups) and IRC

Guardrail System	Maximum Guardrail System Dimensions ⁽¹⁾	Type	Infill Options	Infill Fastening Description
<i>Evolutions Rail™ Contemporary</i> (Figure 1, Figure 2 & Figure 3)	91" by 42"	Level	1.25" sq., WPC baluster with polymer cap	WPC balusters are fastened to top and bottom rails with a #10-12 x 2-1/2" trim head, type 17 point, with three concentric threads composite deck screw. See Figure 1.
		Level & Stair	<i>CableRail™</i> with <i>Quick-Connect®</i> fittings (swivel for stair), and 0.75" sq. aluminum intermediate balusters	Stainless steel cables are attached to each post sleeve with Quick-Connect® fittings. Cables are installed at 3" and 3-1/16" on center for level and stair rails, respectively. Intermediate, 0.75" square, 0.062" wall thickness, 6063-T6 aluminum balusters are spaced no greater than 30 inches on center along the length of the rail. Balusters are secured to the bottom rail with one #10-12 x 2" pan-head stainless steel screw and the top rail utilizing an intermediate base plate (attaches to the baluster with one #10-12 x 1" flat-head stainless steel screw and attaches to the top rail with two #10-12 x 1" flat-head stainless steel screws. See Figure 2.
			0.75" diameter, hollow, galvanized Q195 steel balusters	Steel balusters are attached to the top and bottom rails utilizing nylon baluster connectors. Nylon baluster connectors are then attached to the top and bottom rails with M4.8 x 38.1 flat-head, coated carbon steel screws for the <i>Contemporary</i> rail or M4.8 x 50.8 flat-head, coated carbon steel screws for the rail <i>Builder</i> . Steel balusters are attached to the top and bottom rails utilizing the nylon baluster connectors. See Figure 3 & Figure 4.
<i>Evolutions Rail™ Builder</i> (Figure 4)	91" by 42"	Level & Stair	0.75" diameter, hollow, galvanized Q195 steel balusters	

⁽¹⁾ Guardrails are qualified up to and including the listed maximum guardrail system dimensions for use in the reference Code Occupancy Classification. Guardrail lengths are actual railing lengths, i.e. clear space between supports for level rails and sloping length of rail between supports for stair rails. Stair rail heights are projected vertically to the leading edge of the stair tread.

Table 3 – Evolutions Rail™ Fastening Schedule

Connection	Fastener	Qty.
Rail Bracket to Post	#10-16 x 2" pan-head, coated, Stainless steel screw	2
Rail Bracket to Rail	#10-16 x 7/8" pan-head, coated, Stainless steel screw	2
Universal Rail to Top Rail Cap (<i>Contemporary Systems</i> only)	#10-16 x 1-1/2" pan-head, coated, Stainless steel screws located every two feet	1
Top Rail Cap to Rail (<i>Builder Systems</i> only)	#10-12 x 2-1/2" trim head, type 17 point, with three concentric threads composite deck screw located every two feet	1
Top Rail Cap to Wood 4x4	#10-12 x 2-1/2" trim head, type 17 point, with three concentric threads composite deck screw	2
Support Block to Bottom Rail	#10-16 x 2" pan-head, coated, Stainless steel screws	2 ⁽¹⁾

⁽¹⁾ Quantity identified is for installation of one support block. Support blocks shall be installed at a spacing of no greater than 23 inches on center.

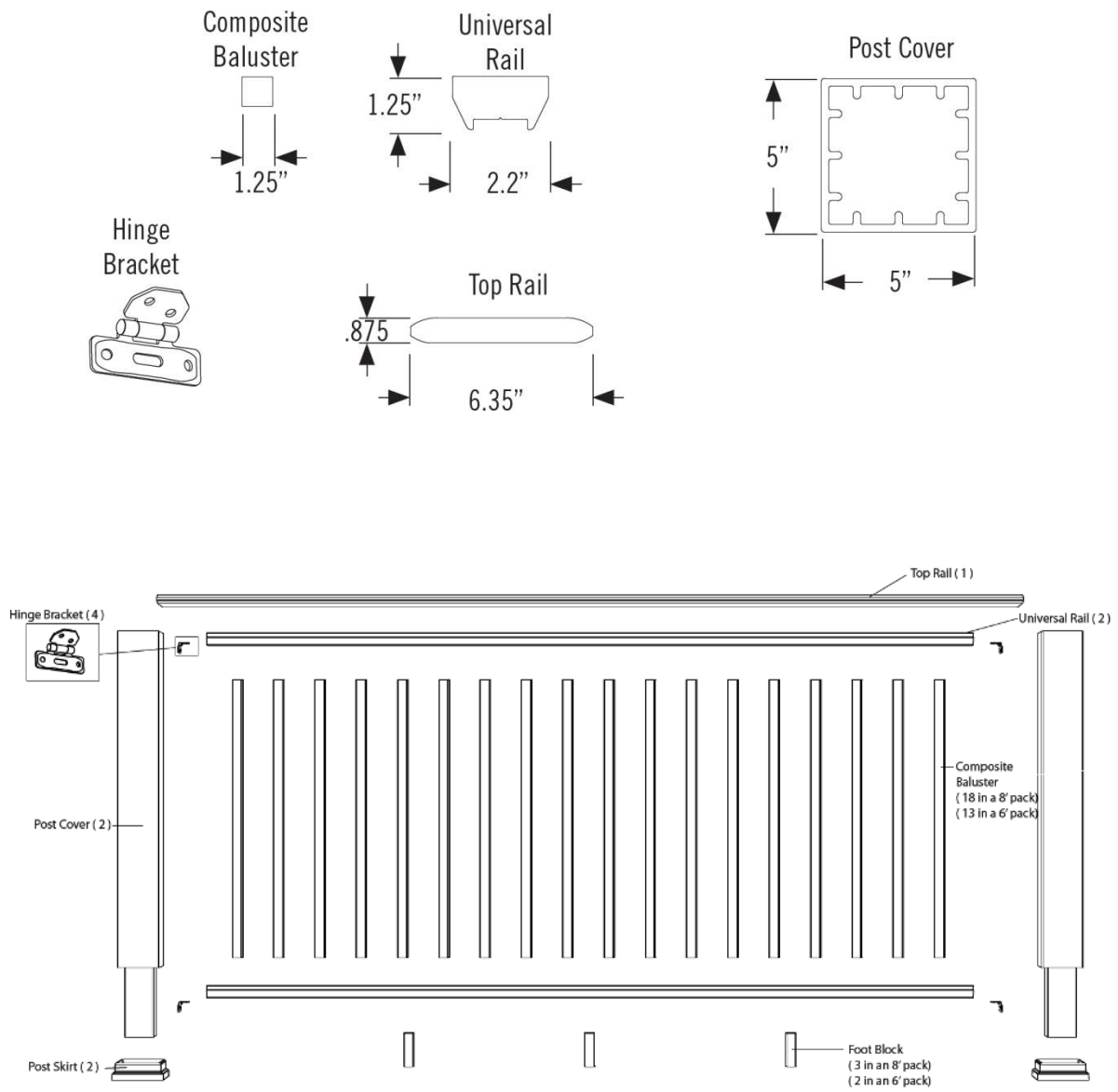

Figure 1 – Evolutions Rail™/ Contemporary with WPC Balusters

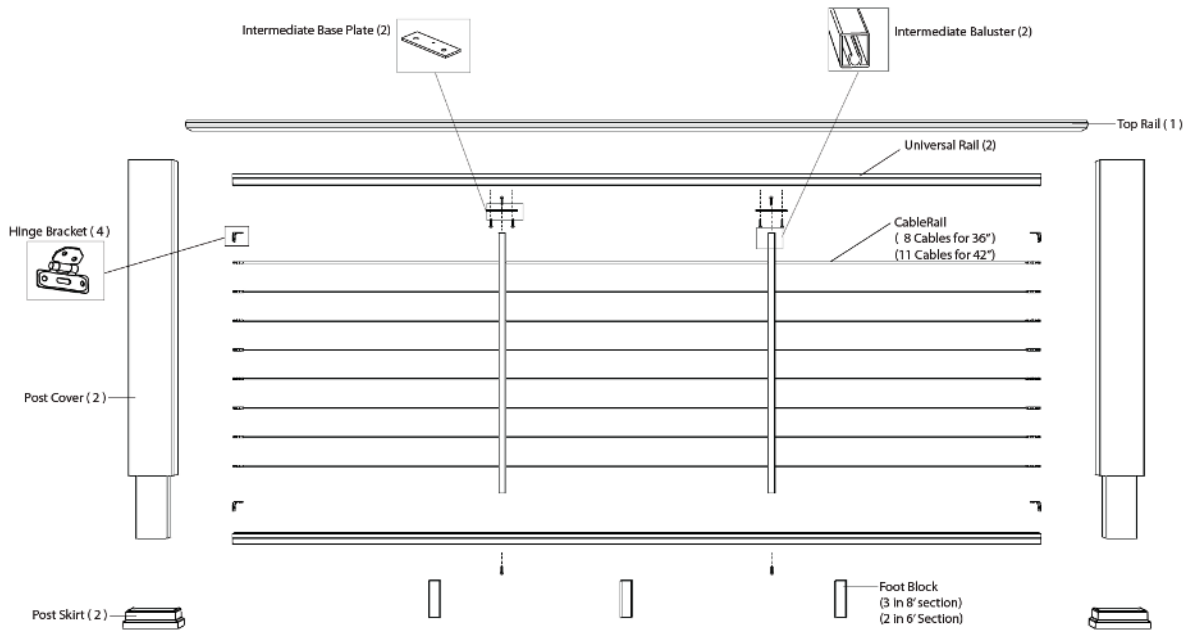
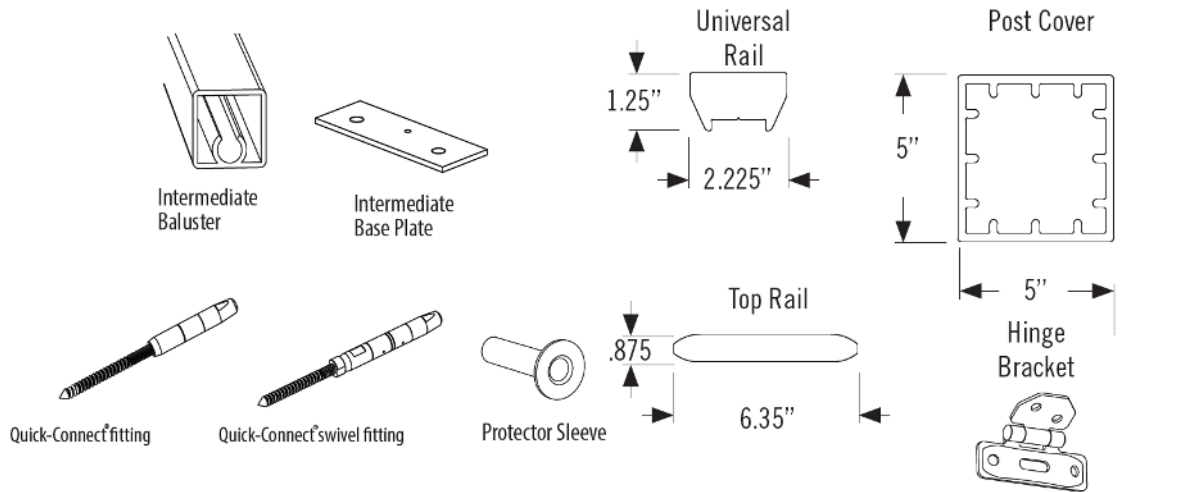

Figure 2 – Evolutions Rail™/ Contemporary with Feeney® CableRail®

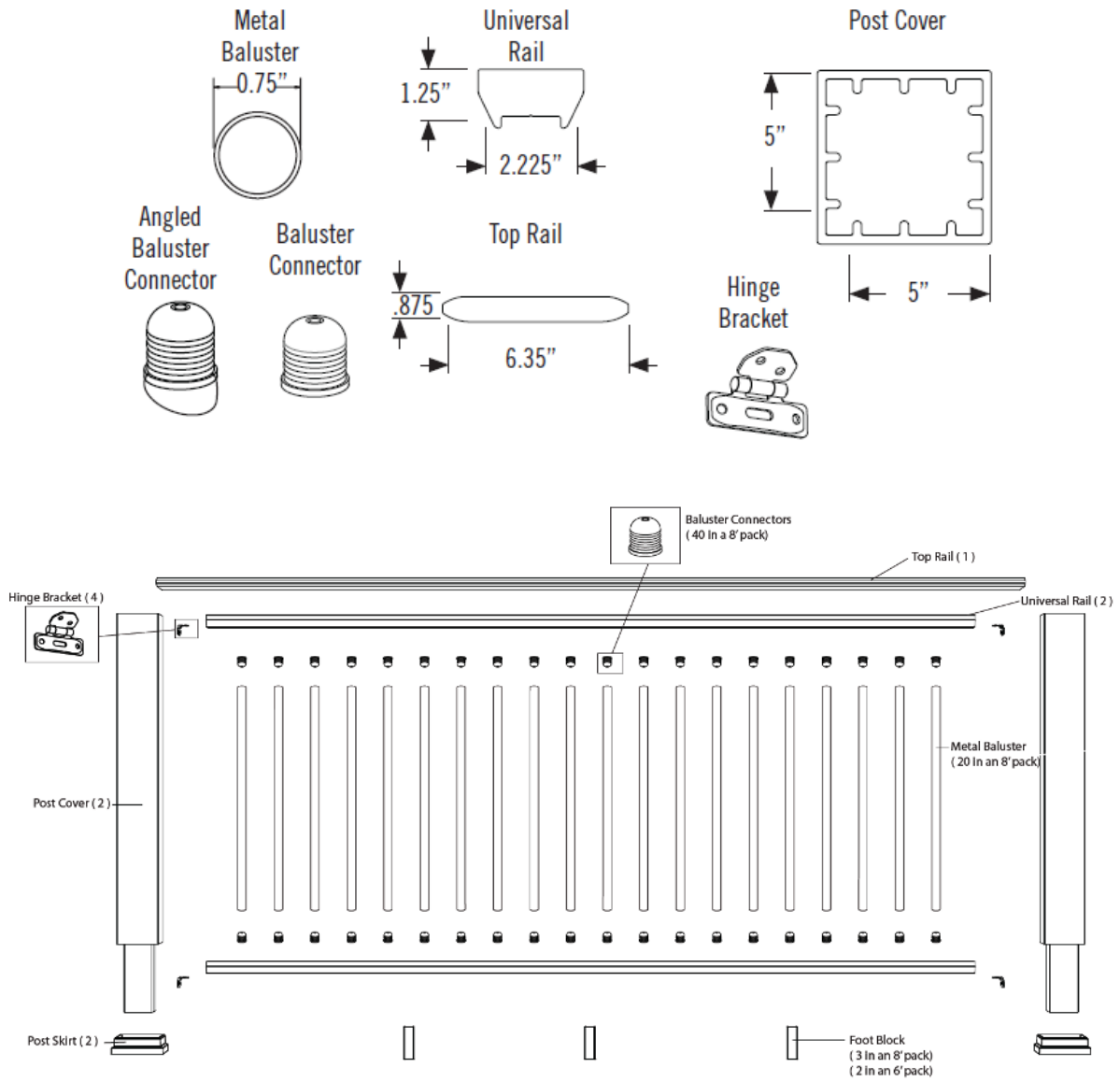

Figure 3 – Evolutions Rail™ / Contemporary with Steel Balusters

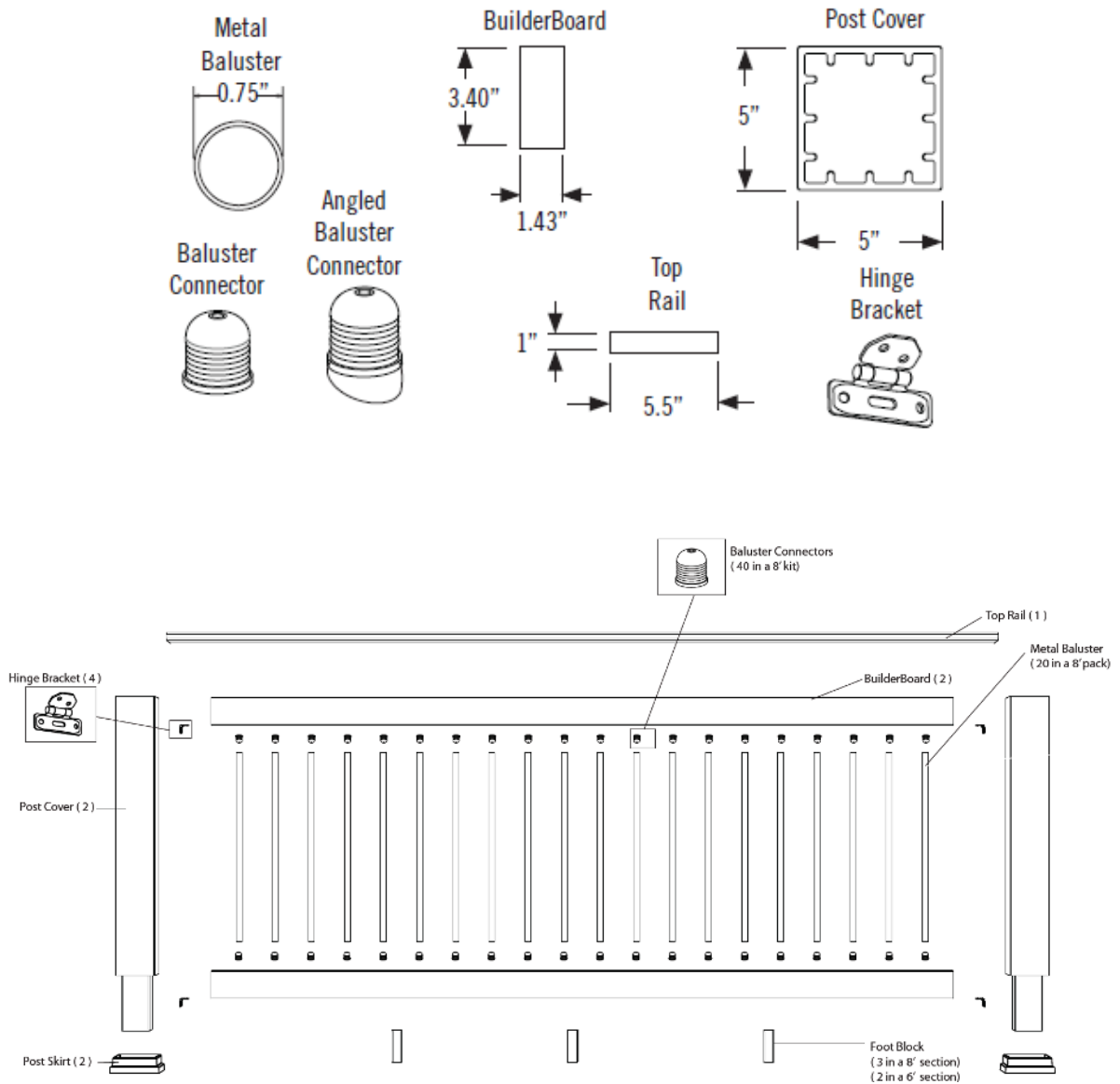

Figure 4 – Evolutions Rail™ / Builder with Steel Balusters