

**DIVISION: 05 00 00 – METALS**  
**Section: 05 52 00 – Metal Railings**

**CPG Building Products LLC**  
894 Prairie Avenue  
Wilmington, OH 45177  
[www.cpgbp.com](http://www.cpgbp.com)

**REPORT SUBJECT:**  
***Impression Rail System***

## 1.0 SCOPE OF EVALUATION

This research report addresses compliance with the following Codes:

- 2015 International Building Code® (IRC)
- 2015 International Residential Code® (IRC)
- 2012 International Building Code® (IBC)
- 2012 International Residential Code® (IRC)

The *Impression Rail System* has been evaluated for the following properties:

- Structural Performance

## 2.0 USES

**2.1.** The *Impression Rail System* is a guard or guardrail under the definitions of the referenced codes. It is intended for use at or near the open sides of elevated walking areas of buildings and walkways as required by the codes.

**2.2.** Guardrail assemblies are provided as level guards for walking areas such as decks, balconies and sloped guardrails are for open sides of stairways.

## 3.0 DESCRIPTION

**3.1.** Level guardrails are provided with rail lengths up to 120 inches in length and installed heights of 42 inches measured from the top of the upper rail to the walking surface. See Table 1 for lengths and configurations.

**3.2.** Stair guardrails are provided with rail lengths up to 120 inches measured along the sloping length between the inside of supports and an installed height of 42 inches measured vertically from the top of the upper rail to the leading edge of the stair tread or landing. See Table 1 for lengths and configurations.

**3.3.** The *Impression Rail System* is an assemblage of aluminum top rails, bottom rails, rail inserts, brackets, pickets, posts and a wood plastic extruded composite post sleeve.

**3.3.1.** The *Impression Rail System* top rails are extruded aluminum, 1.8 inch wide by 1.6 inch tall bread loaf profile. Top rails are provided in “Heavy” and “Light” profiles. See Figure 1.

**3.3.2.** The *Impression Rail System* bottom rail is an extruded aluminum, 1.5 inch wide by 1.25 in high profile with 0.05 inch wall thickness. See Figure 1.

**3.3.3.** Top and bottom rail inserts are extruded aluminum profiles, which facilitate slip fit baluster attachment. The top insert is a 1.114 inch by 0.906 inch with 0.65 inch wall thickness. The bottom insert is a 1.168 inches by 0.130 inches profile with 0.08 inch wall thickness. See Figure 2.

**3.3.4.** The infill area utilizes extruded aluminum balusters with a rectangular 0.57 inch by 0.75 inch profile with 0.05 inch wall thickness. See Figure 3.

**3.3.5.** Rail brackets are available for 90°, 22-1/2° and 45° level rail, fixed stair, adjustable stair (hinged) and over-the-post attachments. See Figure 4.

**3.3.6.** Three variations of the posts are available:

1. Composite post sleeve for installation on conventional 4x4 wood posts.
2. A 2 inch square by 0.13 inch wall extruded aluminum tube, with six internal longitudinal screw chases is attached to a 3.5 inch square by 0.39 inch thick aluminum base plate via six #3/8-18 x 2-1/4 inch long thread cutting flat head machine screws. See Figure 5 and Table 1.



3. A 3 inch square by 0.13 inch wall extruded aluminum tube with eight internal longitudinal screw chases, attached to a 4.5 inch square by 0.5 inch thick aluminum base plate via eight 3/8-18 x 2 inch long thread cutting flat head machine screws. See Figure 6 and Table 1.

**3.3.7.** Foot blocks are extruded aluminum 0.75 inch square profile with a 0.05 inch wall thickness and T-shaped flanges at each interior corner. Round nylon baluster connectors are used to secure foot blocks to railing. See Figure 8.

#### 4.0 PERFORMANCE CHARACTERISTICS

**4.1.** The guardrail system described in this report has demonstrated the capacity to resist the design loadings specified in Chapter 16 of the IBC and Section R301 of the IRC when tested in accordance with ICC-ES AC273.

#### 5.0 INSTALLATION

The *Impressions Rail System* must be installed in accordance with the manufacturer's published installation instructions, the applicable Code and this Research Report. The manufacturer's published installation instructions and this Research Report must be strictly adhered to, and a copy of the instructions must be available on the jobsite during installation.

**5.1.** Guardrails may be assembled in various configurations identified in Table 1. Refer to Table 2 for the fastening schedule of all system components.

**5.2.** Top and bottom rails attach directly to aluminum posts or sleeved conventional wood posts. Wood posts are outside the scope of this report and must be evaluated separately.

**5.2.1.** Rails may be installed at angles of 90°, 45°, and 22-1/2° using angled brackets. See Figure 4.

**5.3.** Balusters are inserted into openings in both the bottom and top inserts.

**5.4.** Guardrails may be attached to conventional 4x4 wood posts, 2 inch square aluminum posts, or 3 inch square aluminum posts.

**5.4.1.** Conventional 4x4 wood posts may be sleeved with an optional 5.5 inch square composite post sleeve.

The composite post sleeve is identified in Intertek Code Compliance Research Report CCRR-0114.

**5.4.2.** For installations limited to the IRC, 2" aluminum posts may be installed on wood decks in accordance with Figure 10 and the following conditions:

**5.4.2.1.** The post shall be installed with the two rows of three base plate attachment screws running perpendicular to the rail (strong axis). See Figure 5.

**5.4.2.2.** Posts shall be anchored to reinforced deck framing with four 3/8 inch by 6 inches long anchor bolts located in the pre-drilled holes in the structural post base plate.

**5.4.2.3.** The deck is constructed with two mounting blocks of nominal 2x8 pressure-treated Southern Yellow Pine installed between 16 inch spaced deck framing beneath the post location. Each 2x8 block is attached to the deck framing with three #9 x 3 inch torx-drive flat head deck screws per side. See Figure 10.

**5.4.2.4.** A 0.39 inch thick, 4.5 inch square aluminum installation plate is installed on the underside of the 2x8 wood mounting blocks.

**5.4.2.5.** All aluminum components in contact with wood shall be factory painted or given a heavy coat of alkali-resistant bituminous paint to provide barrier protection from moisture absorbed in wood.

**5.4.3.** For 2 inch or 3 inch aluminum post installation on concrete or other rigid supports (such as structural steel), the installation uses four 3/8 inch diameter anchor bolts located in the pre-drilled holes in the structural post base plate. The type and length of the anchor bolts is dependent upon the material and condition of the supporting structure and is not within the scope of this report. See section 7 for Conditions of Use for additional requirements.

**5.5.** A foot block is installed between the lower rail and the deck surface. Applications shorter than 72 inches require one foot block located at the mid-span and applications longer than 72 inches require two foot blocks evenly spaced.

#### 6.0 SUPPORTING EVIDENCE

**6.1.** Drawings and installation instructions submitted by the manufacturer.



Intertek

130 Derry Court • York • Pennsylvania • 17406

[intertek.com/building](http://intertek.com/building)

ACCREDITED

Product

Certification Agency

PCA-125



**6.2.** Reports of testing demonstrating compliance with the performance requirements of ICC-ES™ AC273, Acceptance Criteria for Handrails and Guards revised March 2016.

**6.3.** Documentation of an Intertek approved quality control system for the manufacturing of products recognized in this report.

## 7.0 CONDITION OF USE

The *Impressions Rail System* described in this Research Report complies with, or is a suitable alternative to, what is specified in those Codes listed in Sections 1.0 and 2.0 of this report, subject to the following conditions:

**7.1.** Installation must comply with this Research Report, the manufacturer's published installation instructions and the applicable Code. In the event of a conflict between the manufacturer's instructions and this report, this report governs.

**7.2.** Compatibility of fasteners and other metallic components with the supporting structure, including chemically treated wood, is outside the scope of this report. Only those types of fasteners and fastening methods described in this report have been evaluated for the installation of the CPG *Impressions Rail System*; other methods of attachment are outside the scope of this report.

**7.3.** Conventional wood guardrail supports including 4x4 posts, and framing are not within the scope of this report and are subject to evaluation and approval by the building official. Supports must satisfy the design load requirements specified in Chapter 16 of the IBC and Section R301 of the IRC. Supports and framing must provide suitable material for anchorage of the rail brackets and post mount, respectively. Where required by the building official, engineering calculations and details shall be provided.

**7.4.** Only those types of fastening methods described in this report have been evaluated for the installation of the railing system described herein; other methods of attachment are outside the scope of this report.

**7.5.** Concrete anchors and anchoring systems for use with the structural posts are not within the scope of this report and are subject to evaluation and approval by the

building official. Anchors must satisfy the design load requirements specified in Chapter 16 of the building code and must meet the following minimum requirements:

**7.5.1.** A minimum of four anchor bolts must be used and located in the four pre-drilled holes in the post base plate.

**7.5.2.** The anchors must be of approved material compatible with the structural post. Anchors in contact with treated wood, must demonstrate compatibility with chemically treated wood in accordance with ICC-ES AC257, Acceptance Criteria for Corrosion-resistant Fasteners.

**7.5.3.** The anchor bolts must have a minimum diameter of 3/8 inch.

**7.6.** When the supporting structure is a wood framed deck, installation must include anchorage to suitable structural framing. Decking is not considered structural framing, and anchorage to decking alone is not an approved installation method.

**7.7.** Where required by the building official, engineering calculations and details shall be provided. The calculations shall verify that the anchorage and supporting structure complies with the building code for the type and condition of the supporting construction.

**7.8.** CPG *Impressions Rail System* is manufactured by CPG Building Products LLC under an approved quality control system that includes independent third party inspections by Intertek (IAS-676).

## 8.0 IDENTIFICATION

**8.1.** The *Impressions Rail System* described in this Research Report shall be identified with labeling on the packaging that includes the following information: The report holder's name (CPG Building Products Inc.)

**8.2.** The following statement for guardrails limited to one and two-family dwellings: "For Use in One- and Two-Family Dwellings Only."

**8.3.** The Intertek Code Compliance Research Report mark and number (CCRR-0238).



Intertek



ACCREDITED

Product  
Certification Agency

PCA-125



## 9.0 CODE COMPLIANCE RESEARCH REPORT USE

**9.1.** Approval of building products and/or materials can only be granted by a building official having legal

authority in the specific jurisdiction where approval is sought.

**9.2.** Code Compliance Research Reports shall not be used in any manner that implies an endorsement of the product by Intertek.

**9.3.** Reference to the Intertek website address: [whdirectory.intertek.com](http://whdirectory.intertek.com) is recommended to ascertain the current version and status of this report.

This Code Compliance Research Report ("Report") is for the exclusive use of Intertek's Client and is provided pursuant to the agreement between Intertek and its Client. Intertek's responsibility and liability are limited to the terms and conditions of the agreement. Intertek assumes no liability to any party, other than to the Client in accordance with the agreement, for any loss, expense or damage occasioned by the use of this Report. Only the Client is authorized to permit copying or distribution of this Report and then only in its entirety, and the Client shall not use the Report in a misleading manner. Client further agrees and understands that reliance upon the Report is limited to the representations made therein. The Report is not an endorsement or recommendation for use of the subject and/or product described herein. This Report is not the Intertek Listing Report covering the subject product and utilized for Intertek Certification and this Report does not represent authorization for the use of any Intertek certification marks. Any use of the Intertek name or one of its marks for the sale or advertisement of the tested material, product or service must first be approved in writing by Intertek.





**TABLE 1 – CODE OCCUPANCY CLASSIFICATION**

Top Rail Type	Guardrail Dimensions <sup>1</sup>		Guardrail Type	Bracket	Post <sup>3,4</sup>	Code Occupancy Classification
	Maximum Length	Maximum Height				
Light	96 inch	42 inch	Level / In-Line	90°	2 in. Aluminum Composite Wood Sleeved 4x4	IRC - One- and Two Family Dwellings  IBC (Limited) <sup>2</sup>
	96 inch	42 inch	Level	45°	Composite Post Sleeved Wood 4x4	
	95-1/4 inch	36 inch	Level / In-Line	Over-The-Top	2 in. Aluminum	
	95-1/4 inch	36 inch	Stair	Over-The-Top	2 in. Aluminum	
	96 inch	42 inch	Level / In-Line	90°	3 in. Aluminum Commercial Composite Sleeved Wood 4x4	IRC - One- and Two Family Dwellings  IBC - All Use Groups
	97-1/2 inch	42 inch	Stair	Fixed Stair Bracket / Adjustable Stair Bracket	3 in. Aluminum Commercial Composite Sleeved Wood 4x4	
	96 inch	42 inch	Level	45°	3 in. Aluminum Commercial	
Heavy	119-3/4 inch	42 inch	Level / In-Line	Over-the-top	2 in. Aluminum	IRC - One- and Two Family Dwellings  IBC (Limited) <sup>2</sup>
	120 inch	42 inch	Level	45°	3 in. Aluminum Commercial Composite Sleeved Wood 4x4	
	120 inch	42 inch	Level / In-Line	90°	3 in. Aluminum Commercial Composite Sleeved Wood 4x4	

<sup>1</sup> Guardrails are qualified up to and including the listed maximum guardrail system dimensions for use in the referenced Code Occupancy Classification. Guardrail lengths are actual railing lengths, i.e. clear space between supports for level rails and sloping length of rail between supports for stair rails. Guardrail height is the overall installed height (top of top rail). For level rails, height is measured from the adjacent walking surface. For stair rails, height is measured vertically from the leading edge of the stair nose.

<sup>2</sup> The use of this product shall be limited to exterior use as a guardrail system for balconies and porches for one- and two-family dwellings of Type V-B (IBC) construction in accordance with the IRC.

<sup>3</sup> The 3 inch posts are limited to concrete installations or other rigid supports such as structural steel.

<sup>4</sup> The 2 inch aluminum posts may be installed on wood deck, concrete surfaces or other rigid supports. Installation on wood decks is limited to uses under the IRC.



Intertek

130 Derry Court • York • Pennsylvania • 17406  
intertek.com/building



ACCREDITED  
Product  
Certification Agency

PCA-125



TABLE 2 – FASTENING SCHEDULE

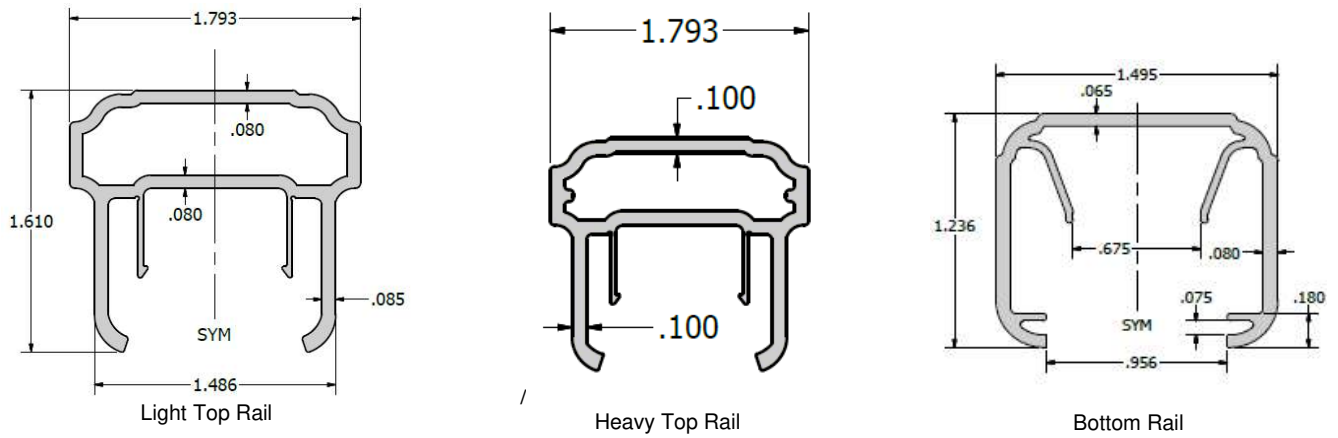
Connection	Fastener
Top/Bottom Level Rail Bracket to Aluminum Post (90°) <sup>1</sup>	Two #10-16 x 3/4 inch (0.132 inch minor diameter) torx drive, pan head, self-drilling, stainless steel screws
Top/Bottom Level Rail Bracket to Aluminum Post (45° and 22.5°/67-1/2°) <sup>1</sup>	Two #10-16 x 1-1/4 inch (0.132 inch minor diameter) torx drive, pan head, self-drilling, stainless steel screws
Top/Bottom Level Rail Bracket to Wood 4x4 Post (90°, 45° and 22.5°/67-1/2°)	Two #10-16 x 3 inch (0.132 inch minor diameter) torx drive, pan head, stainless steel screws
Top/Bottom Level Rail Bracket to Wood 4x4 Post (90°, 45° and 22.5°/67-1/2°)	Two #10-16 x 3 inch (0.132 inch minor diameter) torx drive, pan head, stainless steel screws
Top/Bottom Level and Stair Rail Over-Post Bracket to Post	Two #5/16-18 x 2-1/4 inch long thread-cutting, torx drive, flat head, machine screws
Top/Bottom Stair Rail Bracket (Fixed and Adjustable) to Wood 4x4 Post	Two #10-16 x 3 inch (0.132 inch minor diameter) torx drive, pan head, stainless steel screws
Top/Bottom Stair Rail Bracket (Fixed and Adjustable) to Aluminum Post <sup>1</sup>	Two #10-16 x 1-1/4 inch (0.132 inch minor diameter) torx drive, flat head, self-drilling, stainless steel screws
Adjustable Stair Rail Hinge Attachment	One 1-3/4 inch long x 13/64 inch diameter barrel, truss head hex bolt with #8-32 x 3/8 inch square drive, pan head, stainless steel screw
Adjustable Stair Rail Saddle Bracket to Plate <sup>2</sup>	Two #10-24 x 13/32 inch torx drive, pan head, stainless steel screws
Top Level and Stair Rail Bracket to Rail <sup>1</sup>	Two #10-16 x 3/4 inch (0.132 inch minor diameter) torx drive, flat head, self-drilling, stainless steel screws
Foot Block to Adaptor	No mechanical connection – slip fit
Foot Block Adaptor to Rail <sup>1</sup>	One #10-16 x 1 inch (0.132 inch minor diameter) torx drive, pan head, self-drilling, stainless steel screws
Baluster to Rail	No mechanical connection – pressure fit
Aluminum Post to Wood Deck	Four 3/8 inch x 6 inch hex head, galvanized steel bolts with nut, washer and lock washer

<sup>1</sup> 1/8 inch diameter pre-drill<sup>2</sup> Steel plate pre-drilled and tapped

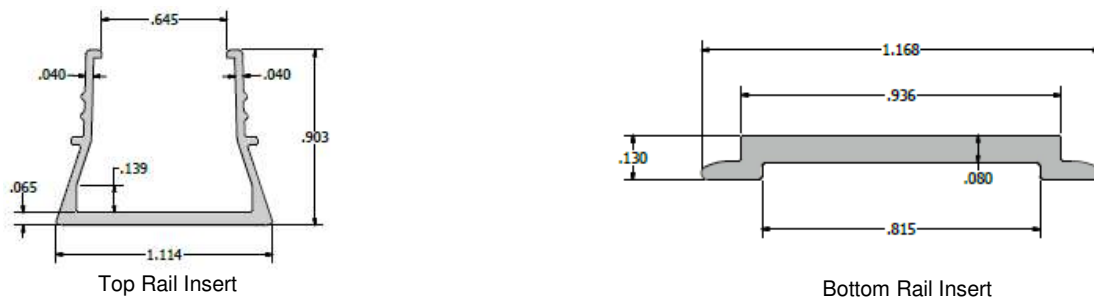
Intertek

ACCREDITED  
Product  
Certification Agency

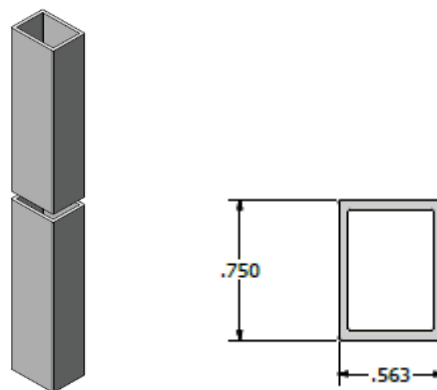
PCA-125



**FIGURE 1: IMPRESSIONS RAIL TOP AND BOTTOM RAIL PROFILES**

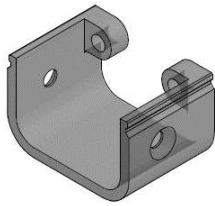


**FIGURE 2: IMPRESSION RAIL TOP AND BOTTOM ALUMINUM RAIL INSERTS**

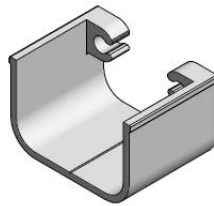


**FIGURE 3: BALUSTER**

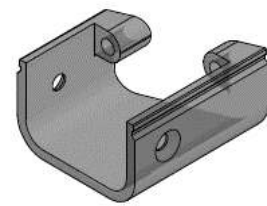




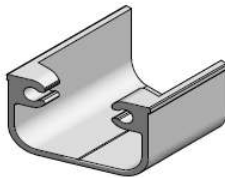
90° Top Rail Bracket



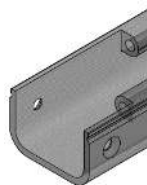
90° Bottom Rail Bracket



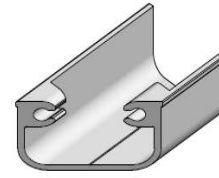
22° Orientation Top Rail Bracket



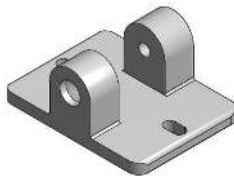
22° Orientation Bottom Rail Bracket



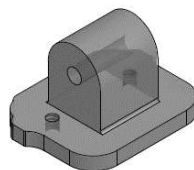
45° Orientation Top Rail Bracket



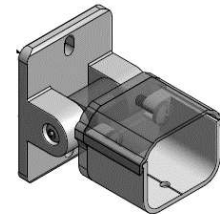
45° Orientation Bottom Rail Bracket



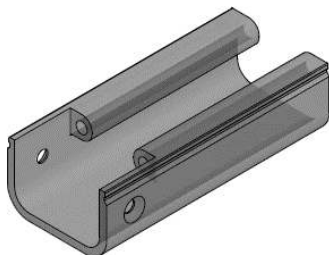
Stair Bracket (Hinged) Part A



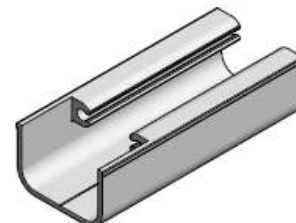
Stair Bracket (Hinged) Part B



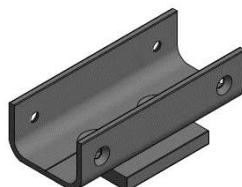
Stair Bracket (Part A and Part B Hinged Assembly) With Bracket and Cover



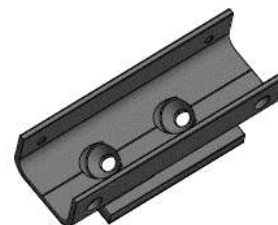
Stair Top Bracket (Fixed – Cut in Field)



Stair Bottom Bracket (Fixed – Cut in Field)



Over the Post Level Bracket



Over the Post Stair Bracket

**FIGURE 4: BRACKETS**



Intertek



ACCREDITED  
Product  
Certification Agency

PCA-125



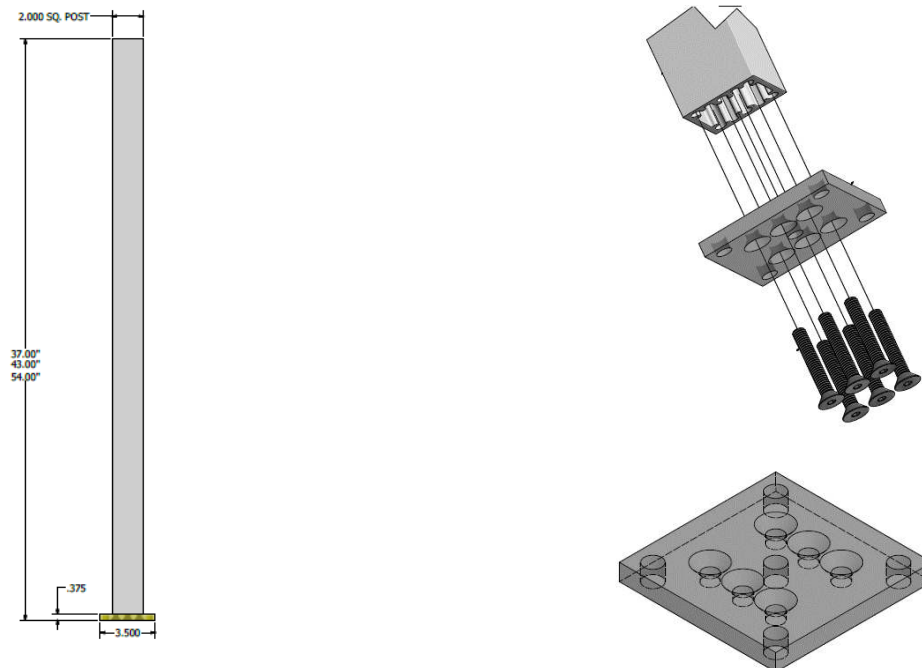


FIGURE 5: 2 INCH POST AND POST PLATE

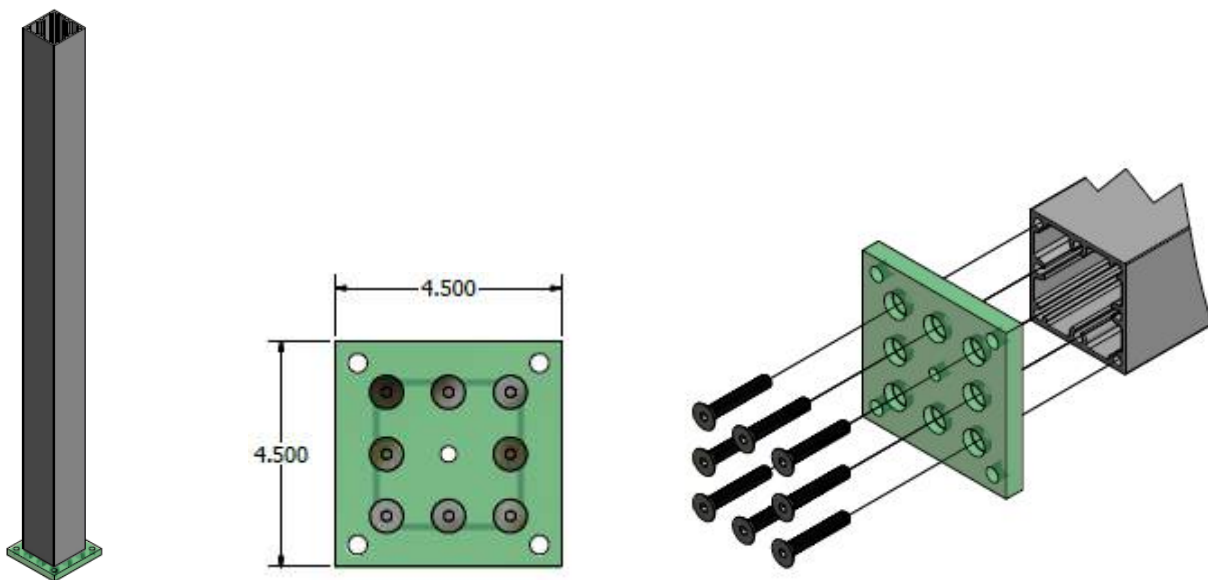
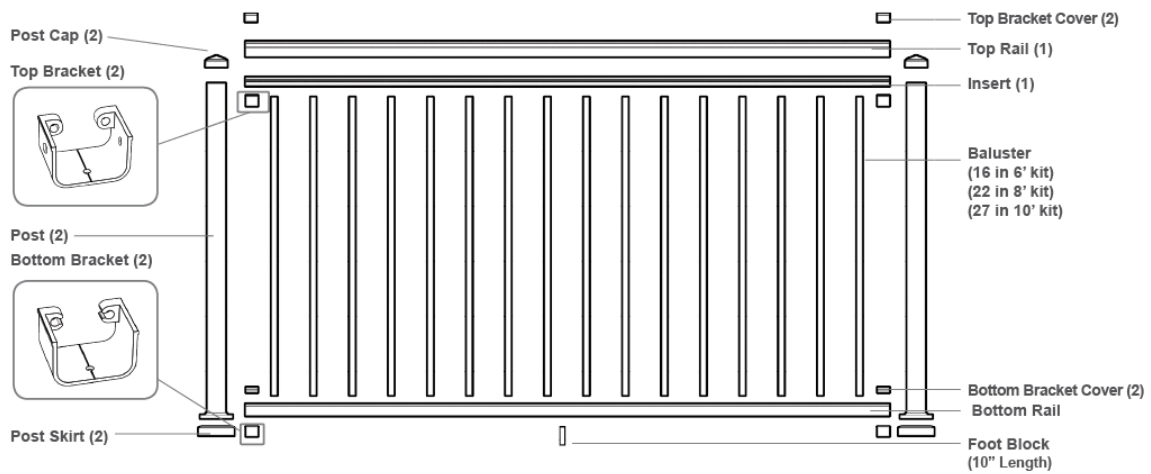
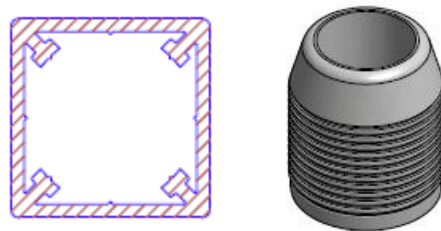


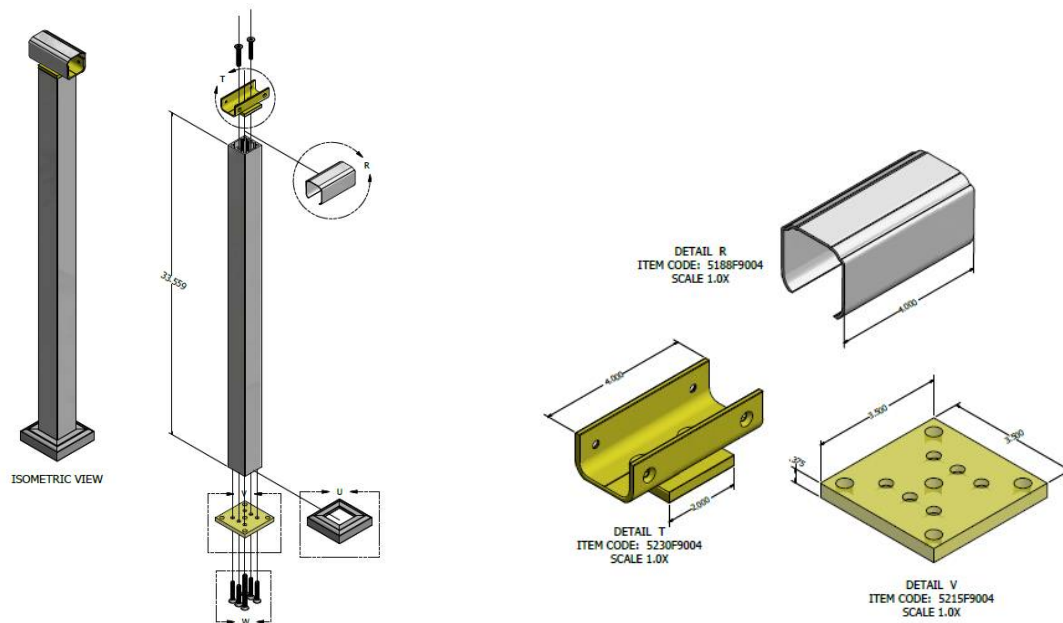
FIGURE 6: 3 INCH POST AND POST PLATE



**FIGURE 7: IMPRESSIONS RAIL ASSEMBLY**



**FIGURE 8: 3/4" X 3/4" FOOT BLOCK PROFILE AND FOOT BLOCK CONNECTOR**



**FIGURE 9: OVER THE TOP POST ASSEMBLY**

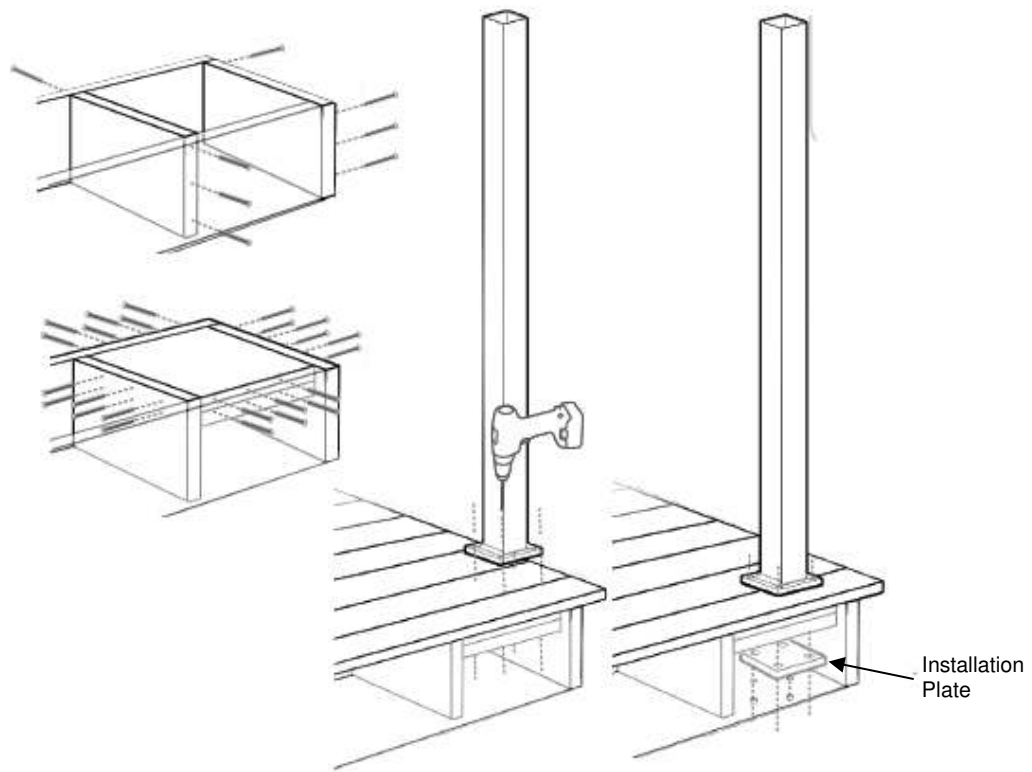


FIGURE 10: POST MOUNT BLOCKING AND INSTALLATION ON WOOD DECKING

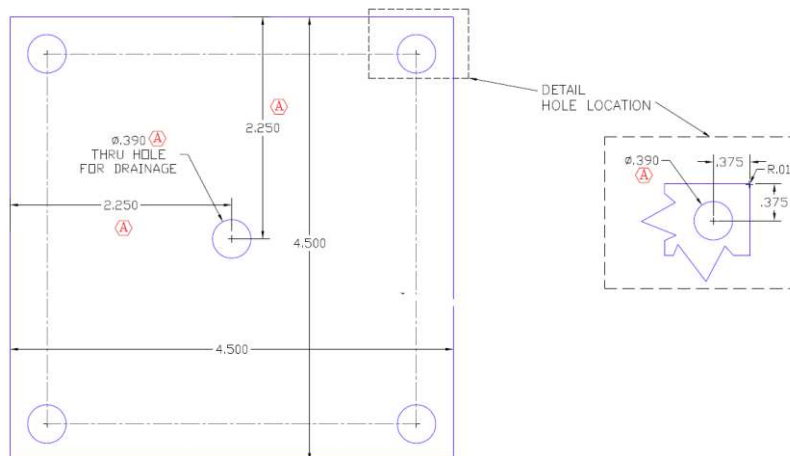


FIGURE 11: INSTALLATION PLATE