



LISTING INFORMATION OF
Intex Millwork Solutions - Cellular PVC Guardrail System
SPEC ID: 33519

INTEX Millwork Solutions LLC.
45 Mill Street
Mays Landing, NJ 08330
United States

This report is for the exclusive use of Intertek's Client and is provided pursuant to the agreement between Intertek and its Client. Intertek's responsibility and liability are limited to the terms and conditions of the agreement. Intertek assumes no liability to any party, other than to the Client in accordance with the agreement, for any loss, expense or damage occasioned by the use of this report. Only the Client is authorized to permit copying or distribution of this report and then only in its entirety. Any use of the Intertek name or one of its marks for the sale or advertisement of the tested material, product or service must first be approved in writing by Intertek. The observations and test results in this report are relevant only to the sample tested. This report by itself does not imply that the material, product, or service is or has ever been under an Intertek certification program.

LISTING INFORMATION

Dartmouth RS30, Hampton RS40, Liberty RS60, and Providence RS70 railing systems are guardrails or guards under the definitions of the referenced codes intended for exterior use on elevated walking areas in buildings and walkways as required by the referenced codes.

CODE COMPLIANCE RESEARCH REPORT

Evaluation Method	Building Code	Report Number
ICC- ES AC174 ASTM D7032	2021, 2018, 2015 IBC 2021, 2018, 2015 IRC 2020 FBC	CCRR-0155

Attribute	Value
Code Reports	Yes
Criteria	ICC-ES AC174 (2014)
Criteria	ASTM D7032 (2014)
Criteria	ASTM D7032 (2017)
CSI Code	06 63 00 Plastic Railings
Intertek Services	Certification
Intertek Services	Code Compliance Research Report
Listed or Inspected	LISTED
Listing Section	DECK BOARDS AND RAILINGS
Spec ID	33519

Issue Date: 03-25-2011
Revision Date: 02-23-2023
Renewal Date: 03-31-2024

DIVISION: 06 00 00 – WOOD, PLASTICS AND COMPOSITES
Section: 06 63 00 – Plastic Railings

REPORT HOLDER:

INTEX Millwork Solutions, LLC
45 Mill Street
Mays Landing, New Jersey 08330
(856) 293-4100
www.intexmillwork.com

REPORT SUBJECT:

Intex Millwork Solutions, LLC
Cellular PVC Guard Systems:

- *Dartmouth RS35 Rail System*
- *Hampton RS40 Rail System*
- *Liberty RS60 Rail System*
- *Providence RS70 Rail System*

1.0 SCOPE OF EVALUATION

1.1 This Research Report addresses compliance with the following Codes:

- 2021, 2018 and 2015 *International Building Code*® (IBC)
- 2021, 2018 and 2015 *International Residential Code*® (IRC)
- 2020 *Florida Building Code* (see Section 9.0)
(Excluding High Velocity Hurricane Zone)

NOTE: This report references 2021 Code sections with [2018, 2015 and FBC] Code sections shown in brackets where they differ.

1.2 *Dartmouth, Hampton, Liberty, and Providence* cellular PVC guard systems have been evaluated for the following properties (see Table 1):

- Durability
- Surface Burning

1.3 *Dartmouth, Hampton, Liberty, and Providence* cellular PVC guard systems has been evaluated for the following uses (see Tables 2 and 3):

- The *Dartmouth, Hampton, Liberty, and Providence* railing systems are guardrails or guards under the definitions of the referenced codes intended for exterior use on elevated walking areas in buildings and walkways as required by the referenced codes. Railing systems are provided as level guards for level walking areas such as decks, balconies, and porches, and sloped guards for open sides of stairways.
- Guard systems recognized in this report may be used in One- and Two-Family Dwellings regulated by the IRC and all construction types regulated by the IBC in accordance with IBC Sections 705.2.2 and 705.2.3.1 [1406.3], Exceptions 2 and 3. Guards less than 42 inches high are limited to use in One- and Two-Family Dwellings (IRC). See Tables 2 and 3 for additional restrictions based upon Use and Occupancy classification.

2.0 STATEMENT OF COMPLIANCE

Dartmouth, Hampton, Liberty, and Providence cellular PVC guard systems comply with the Codes listed in Section 1.1, for the properties stated in Section 1.2 and uses stated in Section 1.3, when installed as described in this report, including the Conditions of Use stated in Section 6.0.

3.0 DESCRIPTION

3.1 Level guards are provided in lengths up to 144 inches and an overall installed height of 42 inches. Stair guards are provided in lengths up to 120 inches between supports projected along the stair slope and 42 inches high projected vertically from the leading edge of the stair tread. See Tables 2 and 3 for qualified configurations.

3.2 Materials and Processes - Railings are an assemblage of extruded components utilizing a cellular Poly Vinyl Chloride (PVC) material, aluminum reinforcements, and stainless-steel mounting brackets.

3.3 The *Dartmouth* systems consist of the following components:



3.3.1 The top rail is either a RS35-400 cap profile with overall dimensions of 4.0 inches wide by 2.34 inches tall or a RS35-350 cap profile 3.5 inches wide by 1.75 inches tall (See Figure 1). Both rails clip to a "baluster cap" 2.75 inches wide by 0.91 inches tall (See Figure 3). For rail lengths greater than 8 feet, the top rail cap is adhered to the baluster cap with Christy's Clear Medium Body PVC Cement, complying with ASTM D2564, continuously applied along the length of the baluster cap.

3.3.2 The bottom rail is a "U" shaped profile with overall dimensions of 3.25 inches wide by 1.75 inches tall with a nominal 0.375-inch wall thickness. See Figure 2.

3.3.3 Top and bottom *Dartmouth* rails are connected to posts with stainless steel brackets secured to the posts with stainless steel screws. See Figure 6 and Table 4.

3.3.4 Extruded aluminum inserts provide reinforcement for the top and bottom rails. See Figure 5.

3.3.5 Infill is provided in two styles: 1.5-inch square extruded solid cellular PVC, or tempered glass balusters with dimensions 3.625 inches wide by 1/4 inch thick. See Figure 4.

3.3.6 Support blocks for the *Dartmouth* rail system are cut from 1.5 inches by 1.5 inches square balusters and attached to the bottom rail every 36 inches.

3.4 The *Hampton* systems consist of the following components:

3.4.1 Top rails consist of two styles of rail caps. The top flat rail cap is 7/8 inches high by 3.5 inches wide flat profile over a top rail base that is 1.5 inches high by 2-5/16 inches wide. The peaked rail cap is 1.35 inches high by 3.5 inches wide. See Figure 8.

3.4.2 The bottom rail is "U" shaped profile with overall dimensions of 1.50 inches high by 2.94 inches wide. See Figure 8.

3.4.3 Top and bottom rails are connected to posts with stainless steel brackets secured to the posts with stainless steel screws. See Figure 11 and Tables 5 and 6.

3.4.4 Extruded aluminum inserts provide reinforcement for the top and bottom rails. See Figure 10.

3.4.5 Infill is provided in two styles: 1.25-inch square extruded solid cellular PVC balusters, or tempered glass balusters with dimensions 3.625 inches wide by 1/4 inch thick. See Figure 9.

3.4.6 The support blocks are cut from 1.25 square balusters and attached to the bottom rail every 36 inches.

3.5 The *Liberty* systems consist of the following components:

3.5.1 Top rails consist of two styles of rail caps. The top flat rail cap is 13/16 inches high by 3-1/2 inches wide flat profile over a common rail that is 2-5/8 inches high by 2-3/4 inches wide. The contoured rail cap is 7/10 inches high by 3.5 inches wide. See Figure 12.

3.5.2 The bottom rail is "U" shaped profile with overall dimensions of 2-5/8 inches high by 2-3/4 inches wide. See Figure 12.

3.5.3 Extruded aluminum inserts provide reinforcement for the top and bottom rails. See Figure 14.

3.5.4 Top and bottom rails are connected to posts with stainless steel brackets secured to the posts with stainless steel screws. See Figure 15 and Table 7.

3.5.5 Liberty RS60 infill is provided in three styles: 1.25-inch square extruded solid cellular PVC balusters, tempered glass balusters with dimensions 3.625 inches wide by 1/4 inch thick, or 3/4-inch dia. aluminum balusters. Liberty RS60-H infill is provided in one style: 1.25-inch square extruded hollow cellular PVC balusters. See Figure 13.

3.5.6 The support blocks are cut from 1.25 square balusters and attached to the bottom rail every 36



inches for 96 inch long rail systems and every 30 inches for 120 inch long rail systems.

3.6 The *Providence* systems consist of the following components:

3.6.1 The top rails consist of one style of rail cap. The top flat rail cap is 3/4 inches high by 3-3/4 inches wide over a common rail that is 1-1/2 inches high and 2-3/4 inches wide. See Figure 16.

3.6.2 The bottom rail is a “U” shaped profile with overall dimensions of 1-1/2 inches high by 2-3/4 inches wide. See Figure 16.

3.6.3 Extruded aluminum inserts provide reinforcement for the top and bottom rails. See Figure 18.

3.6.4 Top and bottom rails are connected to the posts fastened with stainless steel brackets. See Figure 19.

3.6.5 Infill is provided in three styles: 1.5-inch square extruded solid cellular PVC balusters, 1.25-inch square extruded solid cellular PVC balusters, or tempered glass balusters with dimensions 3.625 inches wide by 1/4 inch thick. See Figure 17.

3.6.6 Support blocks are 1.25-inch square extruded rigid cellular PVC picket cut to length and secured to the underside of the bottom rail every 36 inches.

3.6.7 Cellular PVC post sleeves have a 3/4-inch wall thickness, non-structural and, provide a vinyl cover for conventional 4x4 wood posts.

4.0 PERFORMANCE CHARACTERISTICS

4.1 The guards listed in this report have demonstrated the capacity to resist the design loads specified in Section 1607.8 of the IBC and R311.7.8.4 of the IRC when tested in accordance with ICC-ES AC174.

4.2 Structural performance has been adequately demonstrated for a temperature range from -20°F to 125°F.

4.3 Materials used are deemed equivalent to preservative treated or naturally durable wood for resistance to weathering effects, decay, and attack from termites.

4.4 Cellular PVC materials used have a flame spread index not exceeding 200 per referenced criterion in AC174.

5.0 INSTALLATION

5.1 General:

Dartmouth, Hampton, Liberty, and Providence cellular PVC guard systems must be installed in accordance with the manufacturer’s published installation instructions, the applicable Code, and this Research Report. A copy of the manufacturer’s instructions must be available on the jobsite during installation.

5.2 Railing assemblies consist of top and bottom rails. Aluminum railing reinforcements are inserted in the rails during assembly as specified for the type and length of railing. See Tables 2 through 8.

5.3 Top and bottom rails are attached to supports with stainless steel brackets that utilize stainless steel screws for anchorage. See Tables 3 through 8 for fastening schedules.

5.4 Railing systems may be attached to conventional wood posts or other suitable wood support structure. Wood in the supporting structure shall have a specific gravity of 0.50 or greater (Southern Yellow Pine or better) and a minimum thickness to allow full penetration of the bracket mounting screws. Conventional wood posts or other wood supports are not within the scope of this report.

6.0 CONDITIONS OF USE

6.1 Installation must comply with this Research Report, the manufacturer’s published installation instructions, and the applicable Code. In the event of a conflict, this report governs.

6.2 Conventional wood guard supports are not within the scope of this report and are subject to evaluation and approval by the building official.

6.3 Conventional wood posts and structural support framing for post installations must satisfy the design load





requirements specified in Chapter 16 of the building code and must provide suitable material for anchorage. Where required by the building official, engineering calculations and details shall be provided.

6.4 Compatibility of fasteners, brackets, and other metallic components with the supporting structure, including chemically treated wood, is not within the scope of this report.

6.5 Only those types of fasteners and fastening methods described in this report have been evaluated for the installation of the INTEX Cellular PVC guards; other methods of attachment are outside the scope of this report.

6.6 The glass in-fill panel of guards is considered a hazardous location as defined by Section 2406.4 of the IBC. Glass must be identified by permanent etching as required by Section 2406.3 of the IBC. Each section of glass must bear the manufacturer's name or mark and the applicable test standard. (Class A of ANSI Z97.1 and Category II of 16 CFR 1201).

6.7 Guards using glass in-fill shall not be used in wind-borne debris regions as defined by the IBC in accordance with Section 2407.1.4.

6.8 The *Dartmouth, Hampton, Liberty, and Providence* cellular PVC guard systems are manufactured under a quality control program with inspections by Intertek Testing Services NA, Inc.

7.0 SUPPORTING EVIDENCE

7.1 Manufacturer's drawings and installation instructions.

7.2 Reports of testing in accordance with ICC-ES AC174, Acceptance Criteria for Deck Board Span Ratings and Guardrail Systems (Guards and Handrails), revised December 2014 with additional testing including increased test loads to address IBC Section 2407.1.1 for assemblies that utilize a glass in-fill panel.

7.3 Reports of testing and engineering analysis demonstrating compliance with ASTM D 7032-17 [14], Standard Specification for Establishing Performance Ratings for Wood-Plastic Composite Deck Boards and Guardrail Systems (Guards or Handrails).

7.4 Documentation of an Intertek approved quality control system for the manufacturing of products recognized in this report.

8.0 IDENTIFICATION

The *Dartmouth, Hampton, Liberty, and Providence* cellular PVC guard systems are identified with the manufacturer's name (INTEX Millwork Solutions, LLC), address and telephone number, the product name (*Dartmouth, Hampton, Liberty, and Providence* cellular PVC guard systems), the maximum allowable span rating for the railing assembly, and when applicable, the statement "For Use in One- and Two-Family Dwellings Only.", the Intertek Mark as shown below, and the Code Compliance Research Report number (CCRR-0155).





9.0 FLORIDA BUILDING CODE

9.1 Scope of Evaluation:

The Dartmouth, Hampton, Liberty, and Providence cellular PVC guard systems were evaluated for compliance with the Florida Building Code – Building, and Florida Building Code – Residential.

9.2 Conclusion:

The Dartmouth, Hampton, Liberty, and Providence cellular PVC guard systems described in Sections 2.0 through 7.0 of this Research Report, comply with the Florida Building Code subject to the following conditions:

- Use of the Dartmouth, Hampton, Liberty, and Providence cellular PVC guard systems for compliance with the High-Velocity Hurricane Zone provisions of the Florida Building Code is outside the scope of this Research Report.
- Intertek is an approved evaluation entity and quality assurance entity pursuant to Florida Statute 553.842 – Product Evaluation and Approval.

10.0 CODE COMPLIANCE RESEARCH REPORT USE

10.1 Approval of building products and/or materials can only be granted by a building official having legal authority in the specific jurisdiction where approval is sought.

10.2 Code Compliance Research Reports shall not be used in any manner that implies an endorsement of the product by Intertek.

10.3 Reference to the <https://bpdirectory.intertek.com> is recommended to ascertain the current version and status of this report.

TABLE 1 – PROPERTIES EVALUATED

PROPERTY	IBC SECTION	IRC SECTION	FBC SECTION	FBC-RESIDENTIAL SECTION
Durability	1607	R301	1607	R301
Surface Burning	2603.3	R507.3.2	2603.3	R507.3.2

This Code Compliance Research Report (“Report”) is for the exclusive use of Intertek’s Client and is provided pursuant to the agreement between Intertek and its Client. Intertek’s responsibility and liability are limited to the terms and conditions of the agreement. Intertek assumes no liability to any party, other than to the Client in accordance with the agreement, for any loss, expense or damage occasioned by the use of this Report. Only the Client is authorized to permit copying or distribution of this Report and then only in its entirety, and the Client shall not use the Report in a misleading manner. Client further agrees and understands that reliance upon the Report is limited to the representations made therein. The Report is not an endorsement or recommendation for use of the subject and/or product described herein. This Report is not the Intertek Listing Report covering the subject product and utilized for Intertek Certification and this Report does not represent authorization for the use of any Intertek certification marks. Any use of the Intertek name or one of its marks for the sale or advertisement of the tested material, product or service must first be approved in writing by Intertek.





TABLE 2 – IBC AND FBC GUARD SYSTEMS

Style	Type	Maximum Length ¹	Minimum Height ²	Rail Insert	Infill	Code
<i>Dartmouth</i> (RS35)	Level	144 inches	42 inches	Heavy "U" (Figure 5)	1.5-inch square solid cellular PVC picket	IBC – All Use Groups FBC ⁴ – All Use Groups
	Level	120 inches	42 inches	Light "U" (Figure 5)		
	Stair	96 inches	42 inches ³	Light "U"(Figure 5)		
	Level	96 inches	42 inches	Light "U" (Figure 5)	3.625-inch-wide by 0.25-inch-thick glass balustrade	IBC – All Use Groups FBC ⁴ – All Use Groups
<i>Hampton</i> (RS40)	Level	120 inches	42 inches	"U" Shape (Figure 10)	1.25-inch square solid cellular PVC picket	IBC – All Use Groups FBC ⁴ – All Use Groups
	Stair	96 inches	42 inches ³			
<i>Liberty</i> (RS60)	Level	120 inches	42 inches	"H" Shape (Figure 14)	1.25-inch square solid cellular PVC picket	IBC – All Use Groups FBC ⁴ – All Use Groups
	Stair	96 inches	42 inches ³		3/4-inch dia. aluminum picket	
<i>Liberty</i> (RS60-H)	Level	96 inches	42 inches	"H" Shape (Figure 14)	1.25-inch square hollow cellular PVC picket	IBC – All Use Groups FBC ⁴ – All Use Groups
	Stair	96 inches	42 inches			
<i>Providence</i> (RS70)	Level	120 inches	42 inches	"U" Shape (Figure 18)	1.25-inch square solid cellular PVC picket	IBC – All Use Groups FBC ⁴ – All Use Groups
	Stair	96 inches	42 inches ³			

¹ Maximum length is the actual top rail length measured from the inside of the post to the inside of the post.

² Overall rail height is measured from the top of the top rail to the walking surface or leading edge of the stair tread.

³ Stair construction requires box stringers or other closure beneath bottom rails to prevent clearance that allows passage of a six-inch diameter sphere within the triangle formed by the stair riser and tread.

⁴ Excluding HVHZ, High-Velocity Hurricane Zone





TABLE 3 – IRC AND FBC-R GUARD SYSTEMS

Style	Type	Maximum Length ¹	Minimum Height ²	Rail Insert	Infill	Code
<i>Hampton</i> (RS40)	Level	96 inches	36 inches	“U” Shape (Figure 10)	3.625-inch-wide by 0.25-inch-thick glass balustrade	FBC-R ^{4, 5} IRC ⁴
<i>Liberty</i> (RS60)	Stair	120 inches	36 inches ³	“H” Shape (Figure 14)	1.25-inch square solid cellular PVC picket	FBC-R ^{4, 5} IRC ⁴
					3/4-inch dia. aluminum picket	
	Level	96 inches	42 inches	“H” Shape (Figure 14)	3.625-inch-wide by 0.25-inch-thick glass balustrade	
					3/4-inch dia. aluminum picket	
<i>Liberty</i> (RS60-H)	Stair	120 inches	42 inches ³	“H” Shape (Figure 14)	1.25-inch square hollow cellular PVC picket	FBC-R ^{4, 5} IRC ⁴

¹ Maximum length is the actual top rail length measured from the inside of the post to the inside of the post.

² Overall rail height is measured from the top of the top rail to the walking surface or leading edge of the stair tread.

³ Stair construction requires box stringers or other closure beneath bottom rails to prevent clearance that allows passage of a six-inch diameter sphere within the triangle formed by the stair riser and tread.

⁴ The use of these products shall be limited to one-and two-family dwellings in accordance with the IRC.

⁵ Excluding HVHZ, High-Velocity Hurricane Zone





TABLE 4 - DARTMOUTH ASSEMBLY FASTENING

Connection	Fastener
Top & Bottom Level Rail Bracket to Rail	Four #8 x 1-1/4-inch square-drive T17 18-8SS screws
Top Level Rail Bracket to Post	Three #10 x 3-inch slot-hex washer head TA 18-8SS screws
Bottom Level Rail Bracket to Post	Two #10 x 3-inch slot-hex washer head TA 18-8SS screws
Stair Rail Bracket to Rail	Four #8 x 1-1/4-inch square-drive T17 18-8SS screws
Stair Rail Bracket to Post	Three #10 x 3-inch slot-hex washer head TA 18-8SS screws
Aluminum to Baluster Cap to Rail Cap (RS35-350)	One #8 x 1-7/8-inch square-drive T17 18-8SS screw (one at each end and 1 in center between balusters)
Aluminum to Baluster Cap to Rail Cap (RS35-400)	One #8 x 2-1/4-inch square-drive T17 18-8SS screw (one at each end and 1 in center between balusters)
Aluminum to Baluster Cap to Baluster	One #8 x 2-1/2-inch square-drive T17 18-8SS screw (every three balusters)
Baluster to Baluster Cap	One #8 x 2-1/2-inch square-drive T17 18-8SS screw
Baluster to Bottom Rail	One #8 x 2-1/2-inch square-drive T17-18-8SS screw One #8 x 1-1/2-inch square-drive T17 18-8SS screw
Support Block to Bottom Rail	One #8 x 2-1/2-inch square-drive T17 18-8SS screw



TABLE 5 - HAMPTON ASSEMBLY FASTENING FOR GLASS BALUSTER INSTALLATION

Connection	Fastener
Rail Bracket to Post	(2) #10-11 x 3" (0.131 in minor diameter) hex washer head, slotted drive, stainless steel screws
Rail Bracket to Rail	(4) #8-15 x 1-1/4" (0.117 in minor diameter) square drive, flat head, stainless steel screws
Common Rail to Baluster Retainer ¹	(26) #8-8 x 1-1/2" (0.117 in minor diameter) square-drive, flat-head, type 17-point, stainless steel screw
Common Rail to Aluminum Reinforcing Insert ²	(4) #8-8 x 1-1/2" (0.131 in minor diameter) square-drive, flat-head, type 17-point, stainless steel screw
Bottom Rail to Foot Block	(1) #8-8 x 2-1/2" (0.117 in minor diameter) square-drive, flat-head, type 17-point, stainless steel screw
Baluster to Baluster Retainer	Slip fit into routing - no mechanical connection

¹ Fasteners are located at each end of the rail and two between each baluster.

² Fasteners are located at every third opening between balusters.



TABLE 6 - HAMPTON ASSEMBLY FASTENING FOR 1-1/4" PICKET INSTALLATION

Connection	Fastener
Top Rail Bracket to Post ¹	(2) #12-11 x 4" (0.156 in minor diameter) trim head, phillips drive, stainless steel screws
Top Rail Bracket to Post ²	(2) #10-12 x 3" (0.131 in minor diameter) hex washer head, slotted drive, stainless steel screws
Bottom Rail Bracket to Post ³	(2) #10-12 x 3" (0.131 in minor diameter) hex washer head, slotted drive, stainless steel screws
Top / Bottom Rail Bracket to Rail - Level and Stair (High End)	(4) #8-15 x 1" (0.117 in minor diameter) trim head, square drive, stainless steel screws
Top / Bottom Rail Bracket to Rail - Stair (Low End)	(2) #8-15 x 1" (0.117 in minor diameter) trim head, square drive, stainless steel screws
Baluster to Top Common Rail - Level and Stair	(1) #10-8 x 2-1/2" (0.112 in minor diameter, 0.129 in shank diameter) trim head, square drive, type 17-point, stainless steel screw
Baluster to Common Rail to Aluminum Insert - Level and Stair ⁴	(1) #10-8 x 2-1/2" (0.112 in minor diameter, 0.129 in shank diameter) trim head, square drive, type 17-point, stainless steel screw
Baluster to Bottom Common Rail	(1) #10-8 x 2-1/2" (0.112 in minor diameter, 0.129 in shank diameter) trim head, square drive, type 17-point, stainless steel screw and (1) #8-8 x 1-1/2" (0.112 in minor diameter, 0.129 in shank diameter) trim head, square drive, type 17-point, stainless steel screw
Top Common Rail to Top Rail Cap ⁵	(1) #8-8 x 1-3/4" (0.112 in minor diameter, 0.128 in shank diameter), trim head, square drive, type 17-point, stainless steel screw
Bottom Rail to Foot Block	(1) #10-8 x 2-1/2" (0.112 in minor diameter, 0.129 in shank diameter) trim head, square drive, type 17-point, stainless steel screw

¹ Used for 10 ft level guards and all stair guards.

² Used for level guards 8 ft long and under.

³ Used for all level and stair guards.

⁴ Occurs at balusters 1, 4, and 7 from each end for the stair rail, balusters 1, 4, 7, 10, 13, 16, 19, and 22 for the 10 ft level guard and 2, 5, 8, 11, 14, and 17 for the 8 ft level guard.

⁵ Located between 1st and 2nd baluster and at 1/3rd points for the 10 ft level guard and 8 ft stair guard and between the 1st and 2nd baluster and at the midpoint for the 8 ft level guard.





TABLE 7 - LIBERTY ASSEMBLY FASTENING

Connection	Fastener
Rail Bracket to Post	(2) #10-11 x 3" (0.131 in minor diameter) hex washer head, slotted drive, stainless steel screws
Rail Bracket to Rail	(3) #8-15 x 1-1/4" (0.117 in minor diameter) square drive, flat head, stainless steel screws
Bottom Rail to Foot Block	(1) #8-8 x 2-1/2" (0.117 in minor diameter) square drive, flat head, type 17-point, stainless steel screw
Solid PVC Baluster to Top Support Rail ¹	(1) #8-8 x 2-1/2" (0.117 in minor diameter) square-drive, flat-head, type 17-point, stainless steel screw
Hollow PVC Baluster to Top Support Rail ¹	¼-20 x 1-1/2" Stainless Hex Bolt & Nut
Solid and Hollow PVC Baluster to Common Rail	Slip fit into routing - no mechanical connection
Aluminum Baluster to Top Support and Common Rails	Slip fit into routing - no mechanical connection

¹ Fastening is only required in the 10'/36 section, the 8' section does not require any baluster fastening.



TABLE 8 – PROVIDENCE ASSEMBLY FASTENING

Connection	Fastener
Rail Bracket to Post (96 in Level Rail)	(2) #10-12 x 3" (0.134 in minor diameter) hex washer head, slotted drive, stainless steel screws
Rail Bracket to Post (120 in Level Rail and 96 in Stair Rail)	(2) #12-11 x 4" (0.159 in minor diameter) hex washer head, Hex drive, stainless steel screws
Rail Bracket to Rail	(4) #8-15 x 1-1/4" (0.120 in minor diameter) square drive, flat head, stainless steel screws
Top Common Rail to Baluster	(23 – 120 in Rail), (18 – 96 in Rail) #8-8 x 2-1/2" (0.114 in minor diameter, 0.125 in shank diameter) square-drive, flat-head, Type 17-point, stainless steel screw
Top Common Rail to Aluminum Reinforcing Insert to Baluster ^{1,2}	(7 – 120 in Rail), (6 – 96 in Rail) #8-8 x 2-1/2" (0.114 in minor diameter) square-drive, flat-head, Type 17-point, stainless steel screw
Bottom Common Rail to Baluster	(1) #8-8 x 2-1/2" (0.114 in minor diameter, 0.125 in shank diameter) trim head, square drive, Type 17-point, stainless steel screw and (1) #8-8 x 1-1/2" (0.114 in minor diameter, 0.125 in shank diameter) trim head, square drive, Type 17-point, stainless steel screw
Bottom Rail to Foot Block	(1) #8-8 x 2-1/2" (0.114 in minor diameter, 0.125 in shank diameter) square-drive, flat-head, Type 17-point, stainless steel screw

¹ Fasteners are located at baluster numbers 3, 6, 9, 12, 15, 18 and 21 on the 120 in rail.

² Fasteners are located at baluster numbers 2,5,8,11,14 and 17 on the 96 in rail.

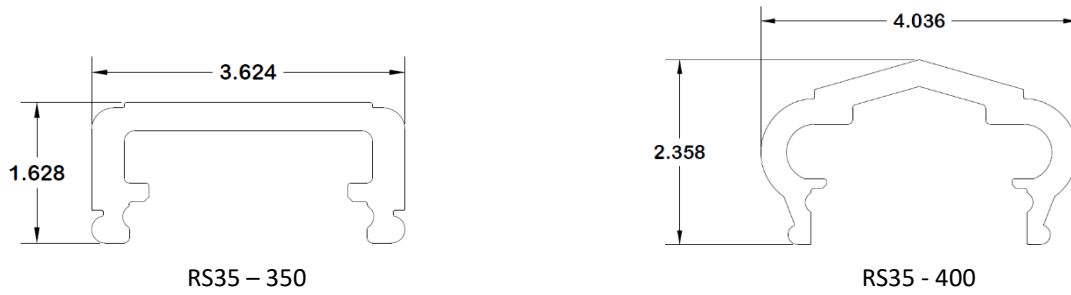

FIGURE 1 – DARTMOUTH TOP RAIL PROFILES

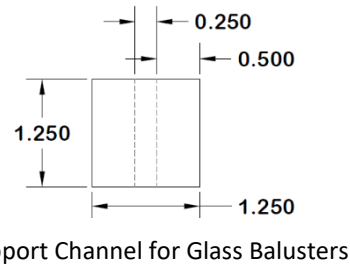
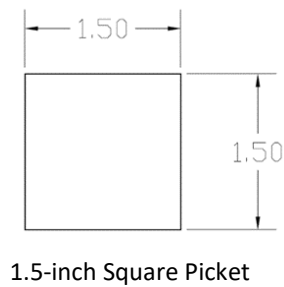
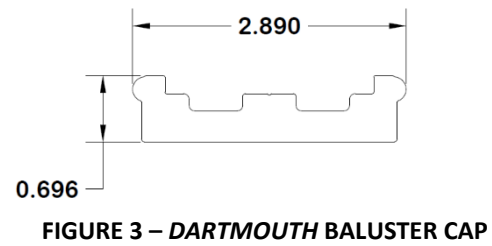
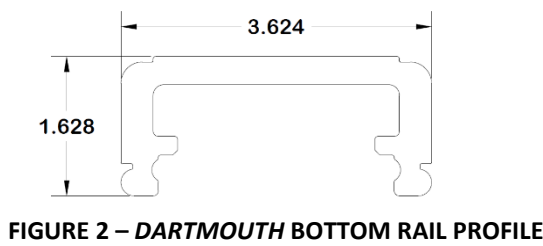

FIGURE 4 – DARTMOUTH INFILL OPTIONS

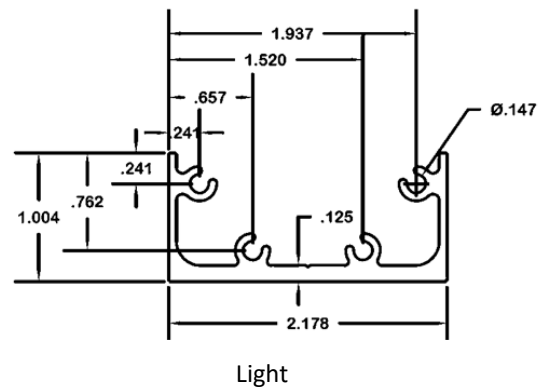
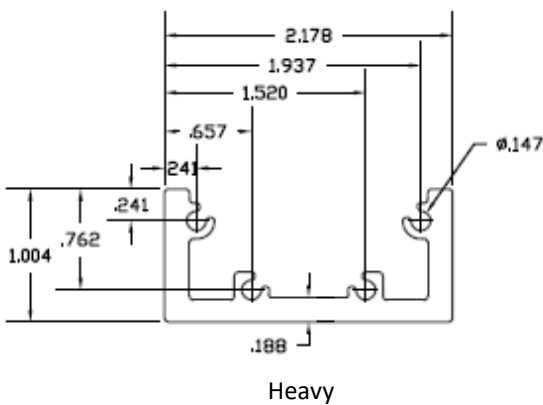
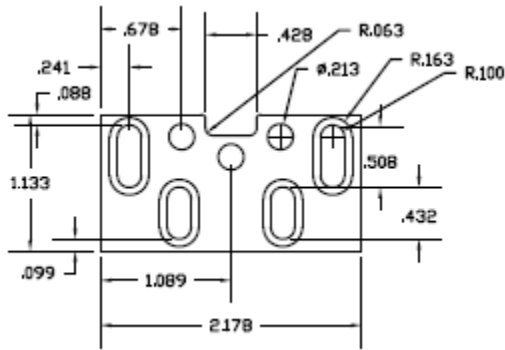
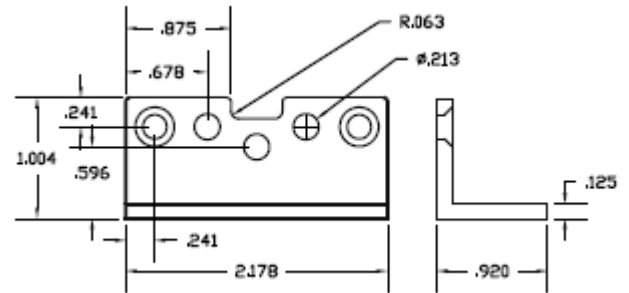

FIGURE 5 – DARTMOUTH ALUMINUM INSERTS





Top Stair Rail Bracket



Bottom Stair Bracket

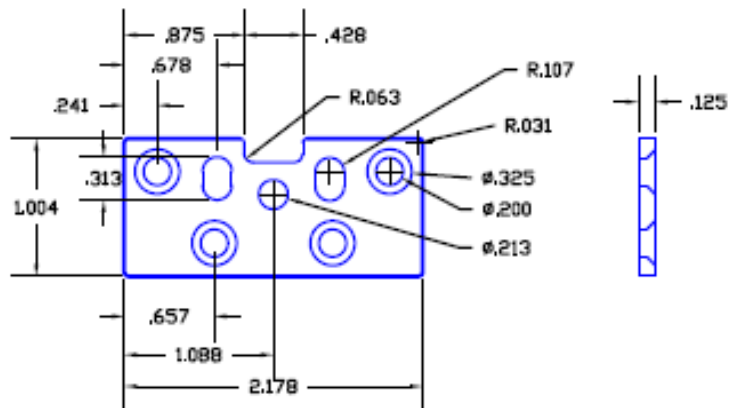

Straight Rail Bracket

FIGURE 6 – DARTMOUTH BRACKETS

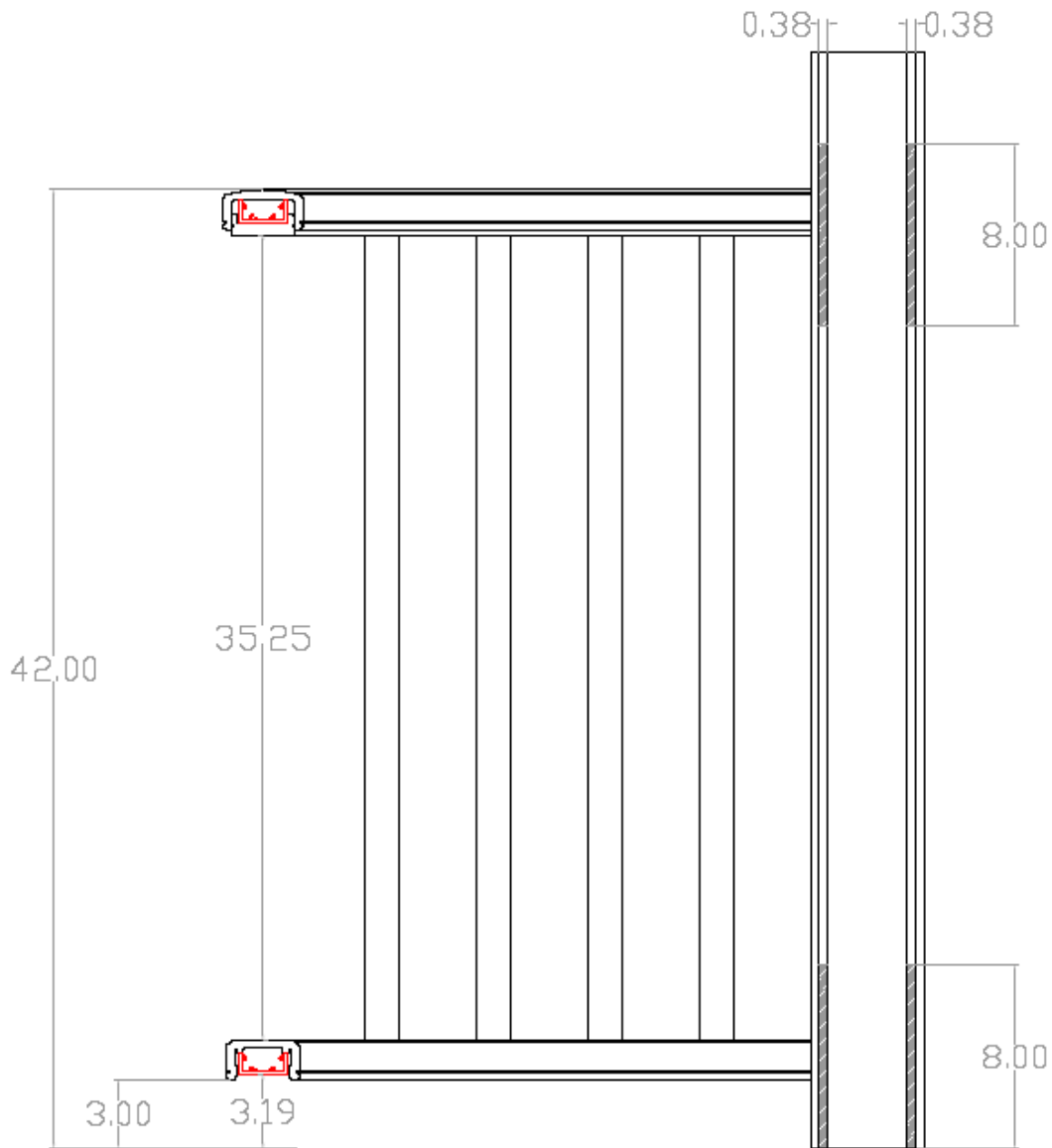

FIGURE 7 – DARTMOUTH TYPICAL LEVEL INSTALLATION TO POST SLEEVE



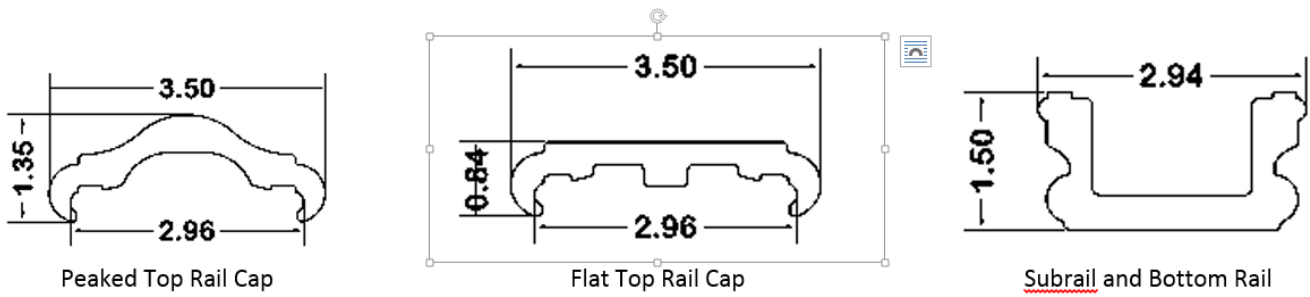

FIGURE 8 – HAMPTON RAIL PROFILES



FIGURE 9 – HAMPTON INFILL OPTIONS

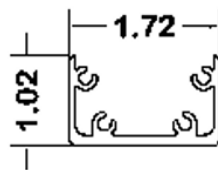

FIGURE 10 – HAMPTON ALUMINUM INSERT

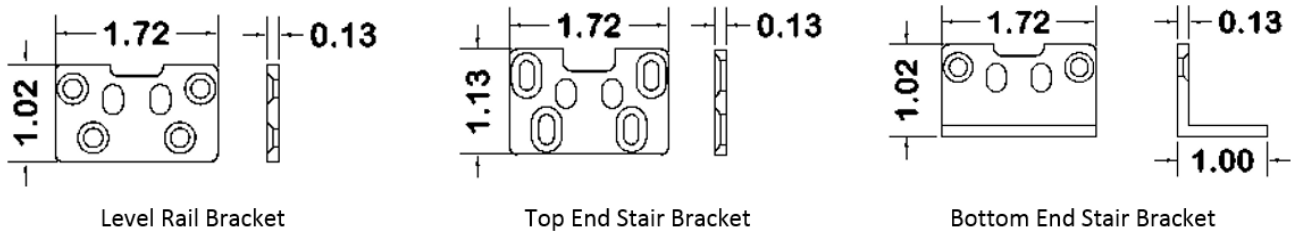
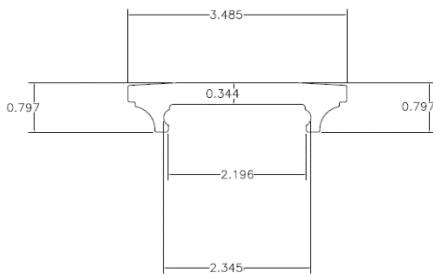
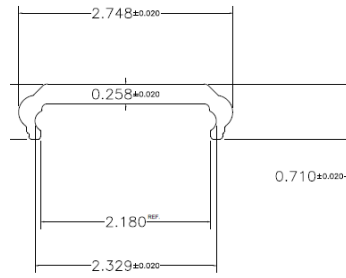

FIGURE 11 – HAMPTON BRACKETS



3.5" Top Rail Cap



2.75" Top Rail Cap

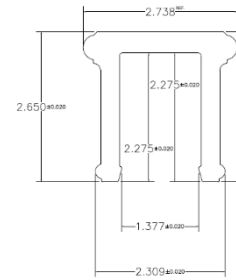

Subrail and Bottom Rail

FIGURE 12 – LIBERTY RAIL PROFILES

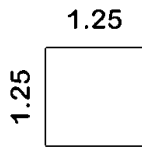

1.25" sq. Solid Picket

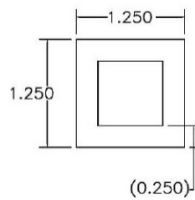

1.25" sq. Hollow Picket (RS60-H)

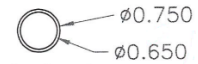

3/4" dia. Aluminum Baluster

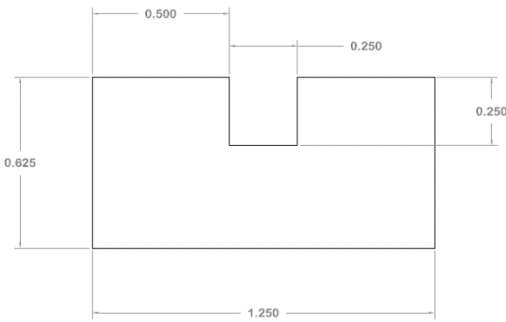

Support Channel for Glass Balusters

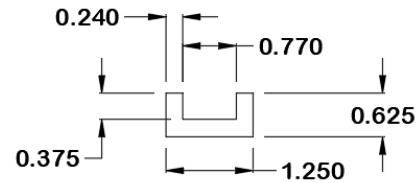
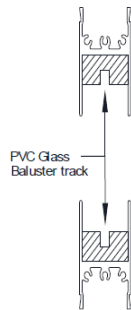

Support Channel for Aluminum Balusters

FIGURE 13 – LIBERTY INFILL OPTIONS

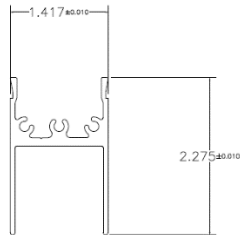

FIGURE 14 – LIBERTY ALUMINUM REINFORCEMENT

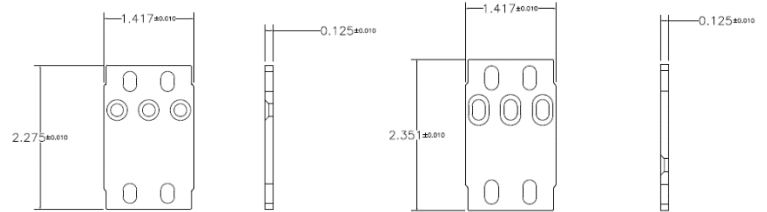

FIGURE 15 – LIBERTY RAIL BRACKETS



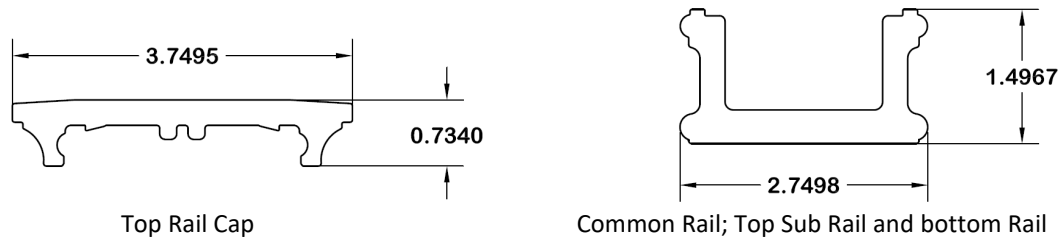

FIGURE 16 – PROVIDENCE RAIL PROFILES

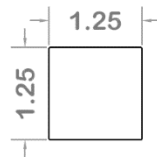

FIGURE 17 – PROVIDENCE 1.25 INCH SQUARE PICKET

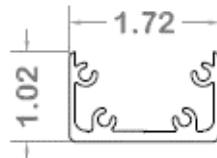

FIGURE 18 – PROVIDENCE ALUMINUM REINFORCEMENT

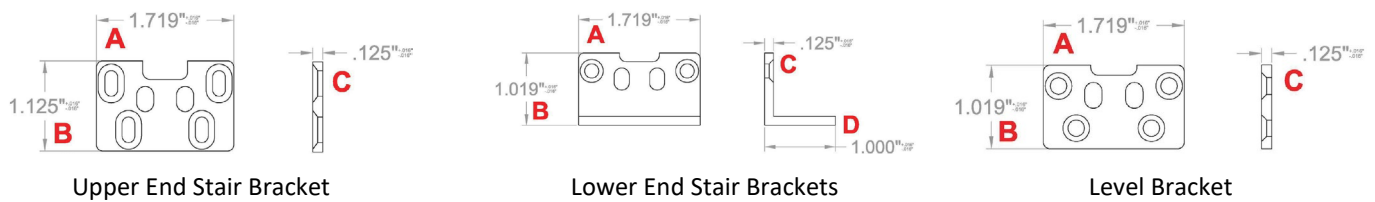

FIGURE 19 – PROVIDENCE BRACKETS