



Aluminium Framing Installation Guide



What Makes TimberTech so Simple to Install?

HIGH STRENGTH

Achieves greater spans than a typical 2" x 10" wood joist or a 2" x 6" steel joist.

EASY HANDLING AND INSTALLATION

Lightweight aluminum joists with tabs for easy handling and alignment. Create a straight and flat deck surface perfect for installing any TimberTech Decking and Railing system.



INDUSTRY LEADING WARRANTY

Will not warp, split, or decay and is highly resistant to rust and corrosion.

To access this information on the website click here. <https://www.timbertech.com/resources/installation-help/>

DISCLAIMER

TimberTech Aluminum Framing should be installed using the same good building principals used to install wood or metal framing and in accordance with the local building codes and the installation guidelines included below. AZEK Building Products LLC and its affiliates accept no liability or responsibility for the improper installation of this product. TimberTech Aluminum Framing may not be suitable for every application and it is the sole responsibility of the installer to be sure that TimberTech Aluminum Framing is fit for the intended use. Since all installations are unique, it is also the installer's responsibility to determine specific requirements for each Deck Framing application. AZEK recommends that all applications be reviewed by a licensed architect, engineer or local building official before installation.

To get more information visit [TimberTech.com](https://www.timbertech.com).

Prior to your purchase, AZEK Building Products LLC also recommends that you see the full installation guidelines for more details regarding installation as well as information on care and maintenance, storage and handling, reference to warranty coverage, and other important product information. Installation Guidelines can be found at:

<https://www.timbertech.com/resources/installation-help/>

Full Assembly

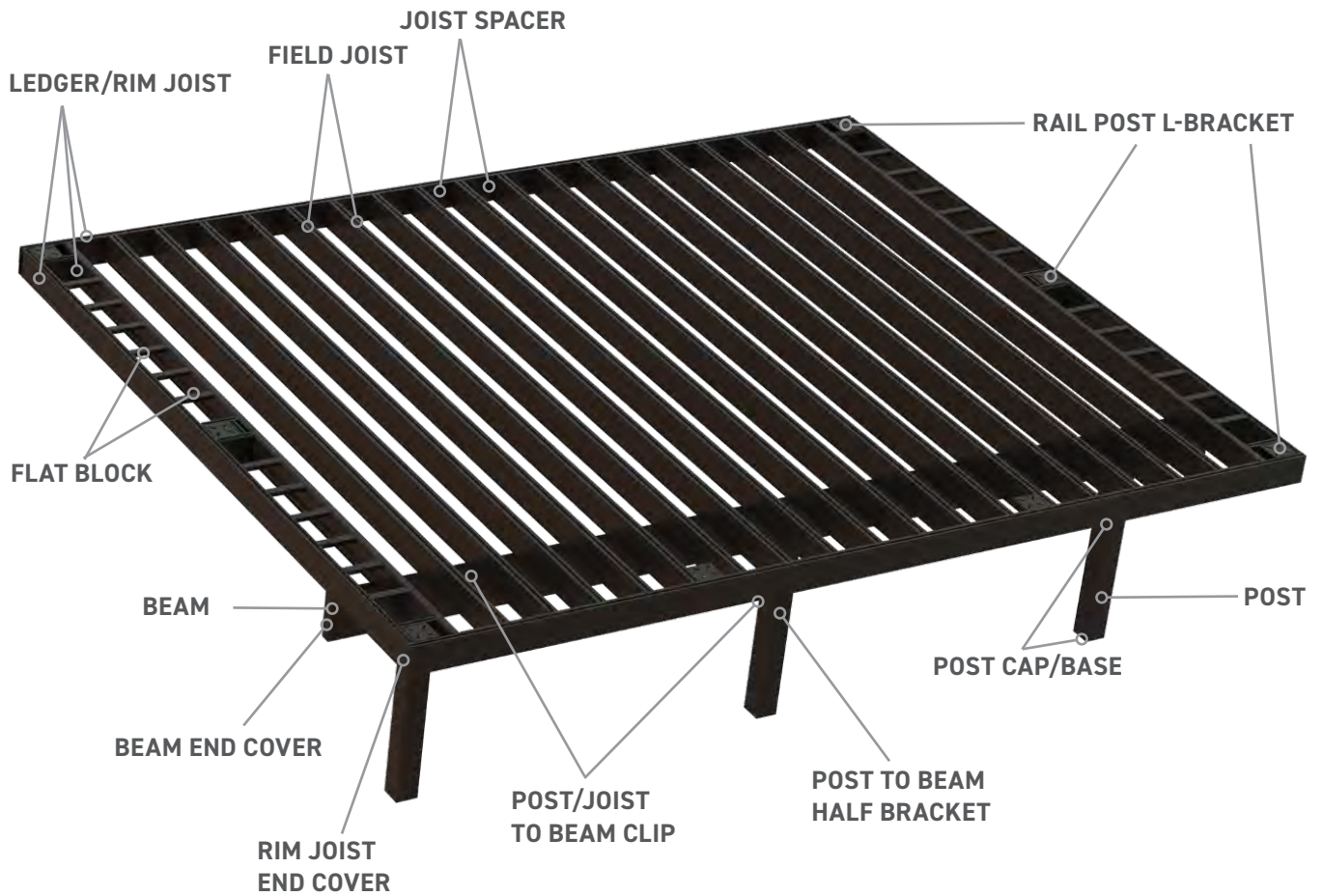

Component Overview

	Item Number	Item Description	Color	Length (ft.)
JOISTS	TFRJ12B	Ledger/Rim Joist (2" x 7-1/4" x 144")	Black	12
	TFRJ16B	Ledger/Rim Joist (2" x 7-1/4" x 192")	Black	16
	TFRJ20B	Ledger/Rim Joist (2" x 7-1/4" x 240")	Black	20
	TFFJ12B	Field Joist (2" x 7-1/4" x 144")	Black	12
	TFFJ16B	Field Joist (2" x 7-1/4" x 192")	Black	16
	TFFJ20B	Field Joist (2" x 7-1/4" x 240")	Black	20

RIM JOIST

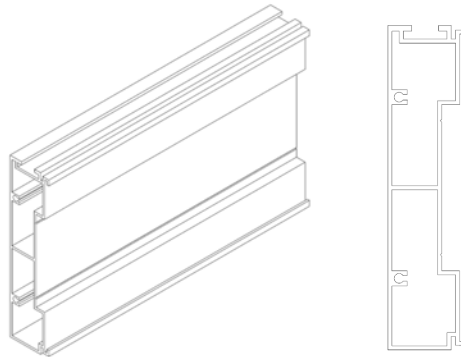

FIELD JOIST

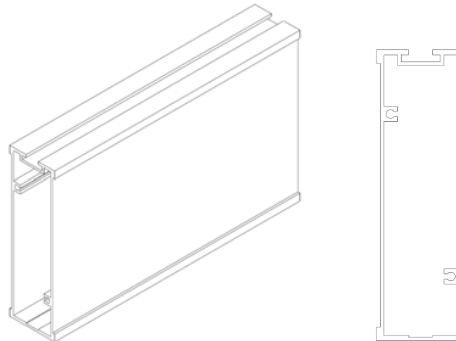

Component Overview

	Item Number	Item Description	Color	Length (in.)
JOIST HARDWARE	TFRJHB	Rim Joist Hanger	Black	1.20
	TFFJHB	Field Joist Hanger	Black	2.00
	TFSP10B	Joist Spacer (10")	Black	10.00
	TFSP14B	Joist Spacer (14")	Black	14.00
	TFUP2B	Uplift Key (2")	Mill Finish	2.00
	TF90ABSB	90 degree Angle Bracket (short)	Black	3.64
	TF90ABTB	90 degree Angle Bracket (tall)	Black	6.45
	TF135ABB	135 degree Angle Bracket	Black	7.23
	TFAABB	Adjustable Angle Bracket	Black	6.52
	TFRAILBB	Rim Joist End Cover	Black	7.25
	TFRJCAPB	Rim Joist Corner Template	Black	7.25
	TFRJTEMPB	Rail Post L-Bracket	Black	6.00



RIM JOIST HANGER

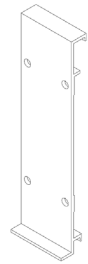

FIELD JOIST HANGER

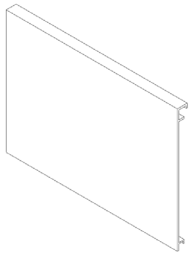

JOIST SPACER

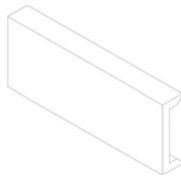

UPLIFT KEY

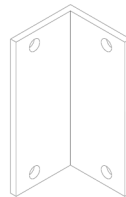

90-DEGREE ANGLE BRACKET SHORT



90-DEGREE ANGLE BRACKET TALL



135-DEGREE ANGLE BRACKET



ADJUSTABLE ANGLE BRACKET



RIM JOIST END COVER



RIM JOIST TEMPLATE

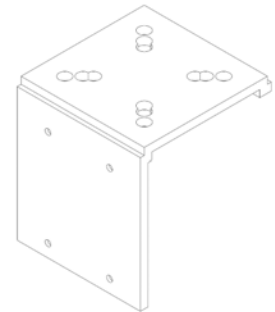

RAIL POST L-BRACKET

Component Overview

	Item Number	Item Description	Color	Length (ft.)
Beams / Posts	TFBEAM12B	Beam (2-3/4" x 11-1/4" x 144")	Black	12
	TFBEAM16B	Beam (2-3/4" x 11-1/4" x 192")	Black	16
	TFBEAM20B	Beam (2-3/4" x 11-1/4" x 240")	Black	20
	TFPOST10B	Post (5-1/2" x 5-1/2" x 120")	Black	10
	TFPOST20B	Post (5-1/2" x 5-1/2" x 240")	Black	20

BEAM

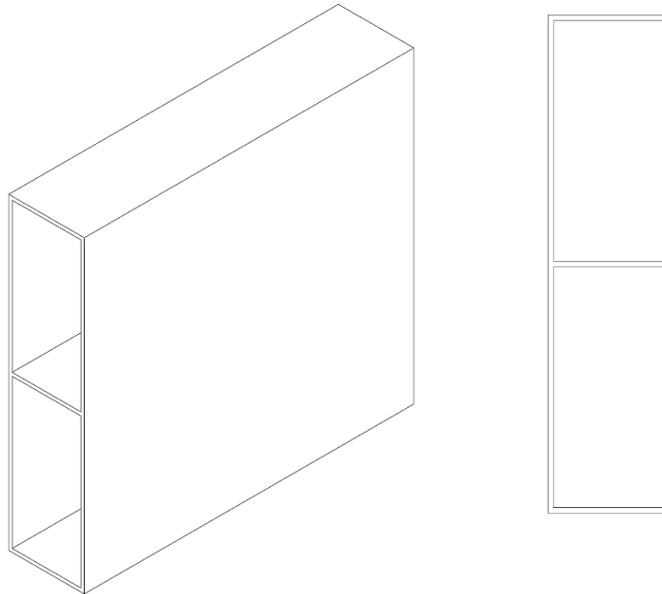

POST

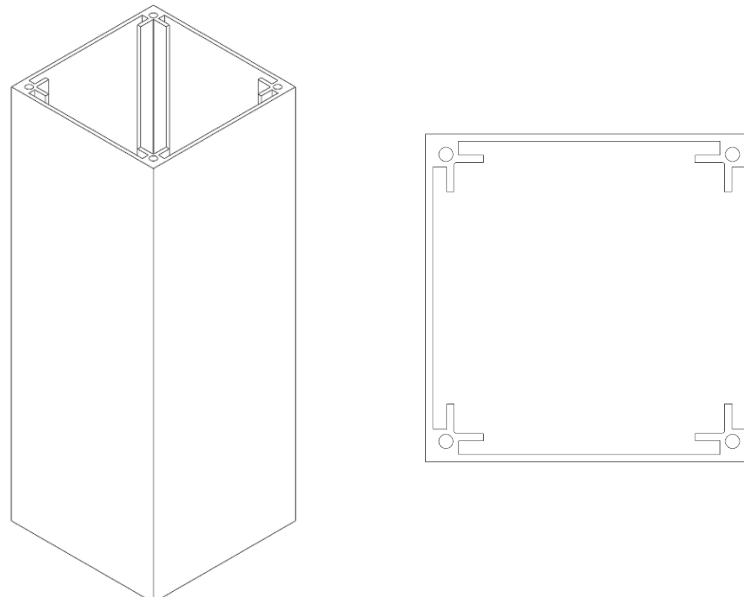

Component Overview

	Item Number	Item Description	Color	Length (in.)
Beams / Post Hardware	TFPCB	Post Cap / Base	Black	5.50
	TFPBB	Post to Beam Half Bracket	Black	4.50
	TFPBJB	Post/Joist to Beam Clip	Black	2.75
	TFBEAMCAPB	Beam End Cover	Black	11.18

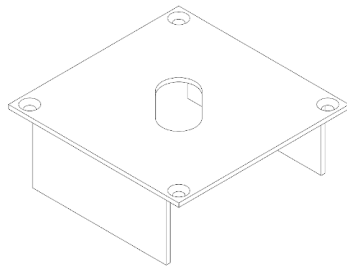

POST CAP

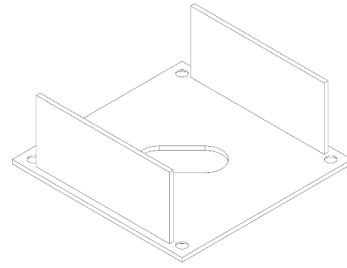

POST BASE

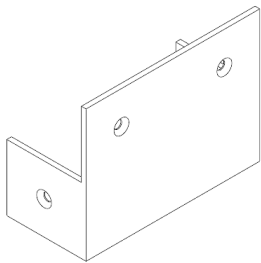

**POST-TO-BEAM
FULL BRACKET**

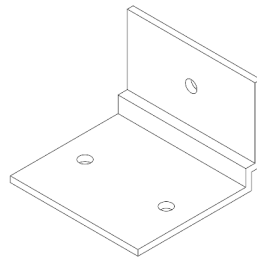

**POST-TO-BEAM/
JOIST-TO-BEAM CLIP**



BEAM END COVER

Component Overview

	Item Number	Item Description	Color
Fasteners	TF50HEX	TimberTech AF 1/4-20 Hex Head Screw (50 screws)	Black
	TF50FLAT	TimberTech AF 1/4-20 Flat Head Screw (50 screws)	Black
	CTX100SFDA	Cortex Drillers for aluminum - 100SF (350 screws, 3 bits, no plugs)	N/A
	TFLOC100	TimberTech AF Hidden Deck Clip 100SF (175 clips, 2 bits)	Black

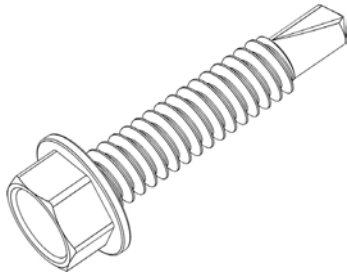

1/4-20 HEX SCREW

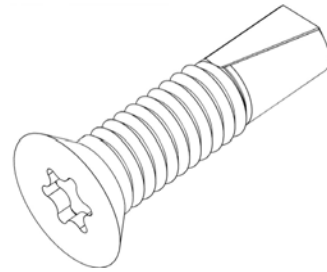

1/4-20 FLATHEAD SCREW

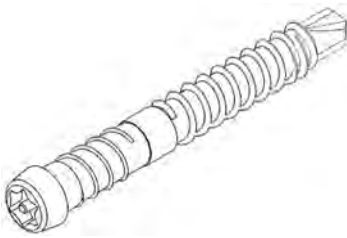

CORTEX DRILLER

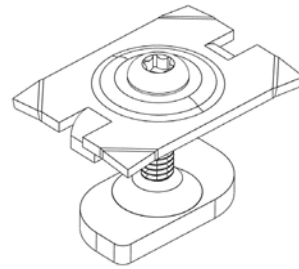

HIDDEN DECK CLIP



Tools Required

- Safety Glasses
- Gloves
- Cordless Impact Driver (20-Volt max)
- 3/8 in. Hex Driver Bit
- T25 Torx/Star Driver Bit
- Miter Saw
- 80-Tooth Laminate/Aluminum Circular Saw Blade
 - Example: DIABLO Model # D1080N or D1296N
- Tape Measure
- Speed Square
- Level and Laser Level (optional)
- String/chalk line
- Pencil/marker
- Clamps
- Magnetic Bit Extender (optional)
- Touch-up Paint (optional)
- Adhesive Caulk (optional - for installing rim joist and beam end covers)
- Adjustable wrench (for installing post bases)

Foundation Preparation

- A properly installed foundation/footing system that is below frost line and meets local code requirements is critical to the appearance and performance of TimberTech framing and decking products.
- Depending on height of deck above grade, and especially in close to grade applications- Excavation may be needed and/or sloping of finished grade to shed water from home/ structure as well as away from the deck framing.
- Always check with local code authorities for specific footing requirements including type, size, and depth requirements in your area.
 - Frost depth requirements will vary geographically (consult code authority in your specific area).
 - There are many options available for footing construction, but final footing type used must be suitable and approved for your specific area/local codes, design, and loading requirement.
- Deck framing/sub-structure must be securely attached to the footing to prevent uplift, lateral movement or shifting of the deck structure.
 - There are many types of connector brackets available on the market to securely attach the framing to footings depending on type of footing used, load capacity needed or other specific requirements. Refer to manufacturer, local building authority, or structural design professional to verify suitable connection for your specific application.
- Examples of acceptable footing systems: poured concrete footings, pre-cast stackable concrete, helical piles, and alternate type piers.

Post and Beam Installation

STEP 1

Attach post bases to pre-installed foundation (poured concrete footing, precast concrete footing, helical pile, or alternate type pier).

Parts required:

- Post Base
- Threaded anchor bolt (1" max) and nut
- Washer (Use neoprene EPDM, bonding washers, or flashing as a barrier between all galvanized steel and aluminum)

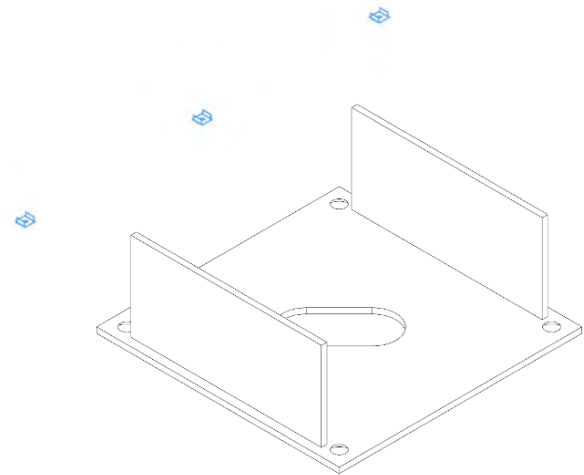

STEP 2

Set each post by sliding the 2" post base tabs into the post slots. Use six self-drilling screws to secure each post to the post base, drilling through the post and into the 2" post base tabs.

The simplest method is to use 1/4-20 Hex head screws. For the cleanest look, use 1/4-20 Flat head screws, which will require creating 82-degree countersunk holes in the post wall.

Parts required:

- Posts
- 1/4-20 x 1" hex head screws
OR flat head screws

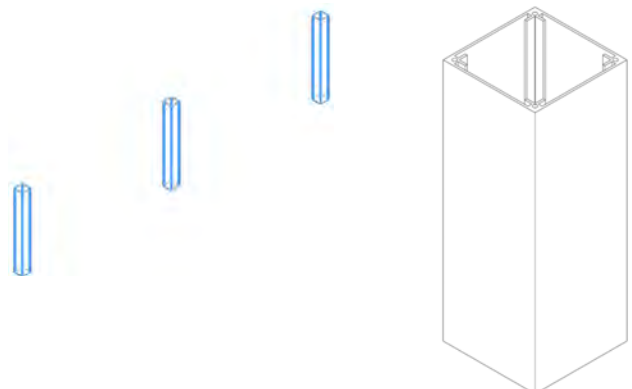

Post and Beam Installation (continued)

STEP 3

Insert a post cap into each post and install four ¼-20 Flat head screws at each countersunk hole.

Ensure that all posts are level and plumb. Make any necessary adjustments prior to proceeding.

Parts required:

- Post Caps
- ¼-20 x 1" flat head screws

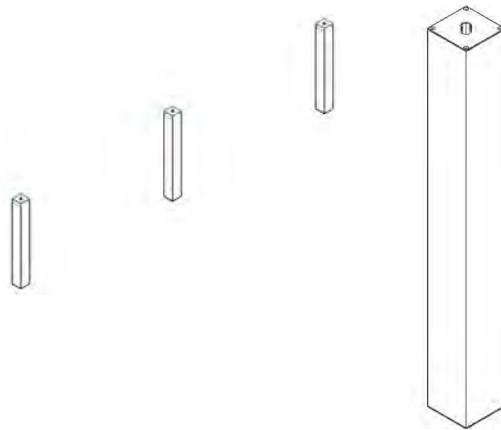

STEP 4

Carefully place the beam on top of the posts. At least two people are needed to safely hold the beam in place prior to fastening.

Two beams may be used to achieve greater spans between the posts.

If a beam splice is required, be sure the splice is centered on a post and that a Beam Clip is installed on the back side of each beam (see Step 6).

Parts required:

- Beam

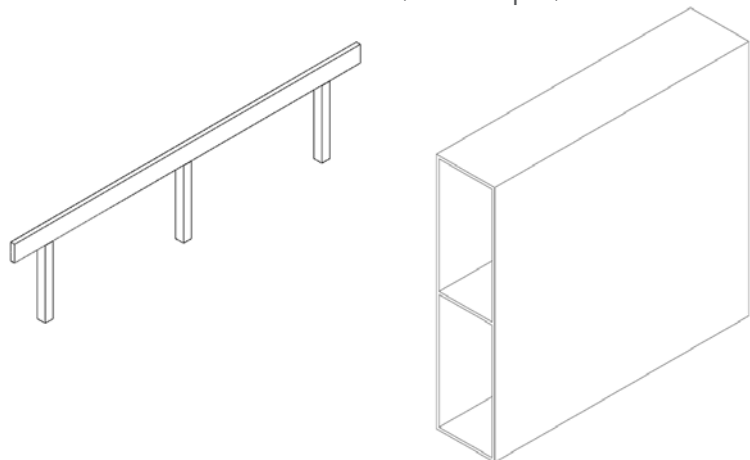

Post and Beam Installation (continued)

STEP 5

Use 1/4-20 Flat head screws to install Post to Beam Half Brackets on the front side of each beam and post. Two screws drill into the front of the beam and two screws drill into the sides of the post. Ensure the front of the beam is flush with the front edge of the post. For double beam configurations, secure the second beam by installing a Post to Beam Half Bracket on the back side of the posts.

Parts required:

- Post to Beam Half Brackets
- 1/4-20 x 1" flat head screws

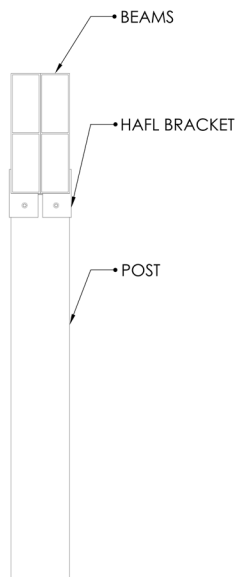
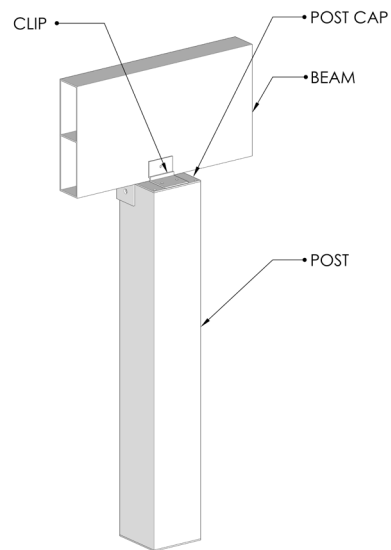
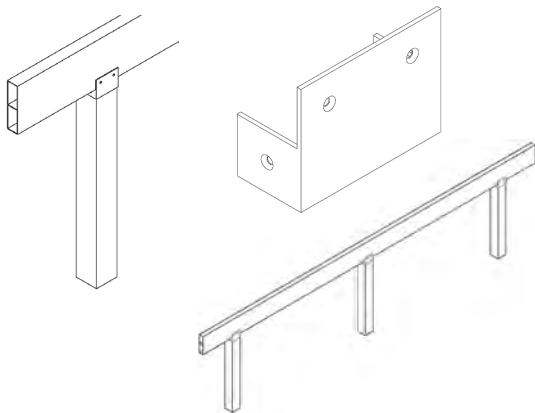

DOUBLE BEAM
SCALE 1:8

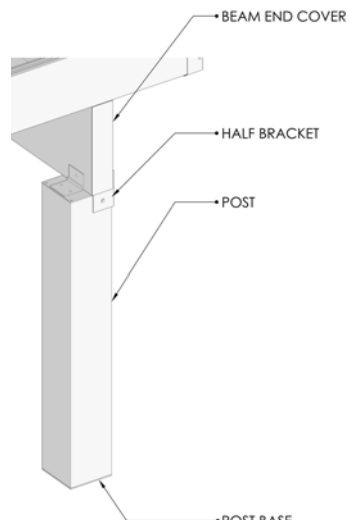

SIDE BEAM
SCALE 1:8

Post and Beam Installation *(continued)*

STEP 6

For a single beam configuration, use ¼-20 Hex head screws to install a Beam Clip on the back side of each beam/post connection. Two screws drill into the Post Cap and one screw drills into the Beam.

For beam splices sharing a single post, install two Beam Clips (one behind each beam).

Parts required:

- Post-to-Beam Clips
- ¼-20 x 1.25" hex head screws

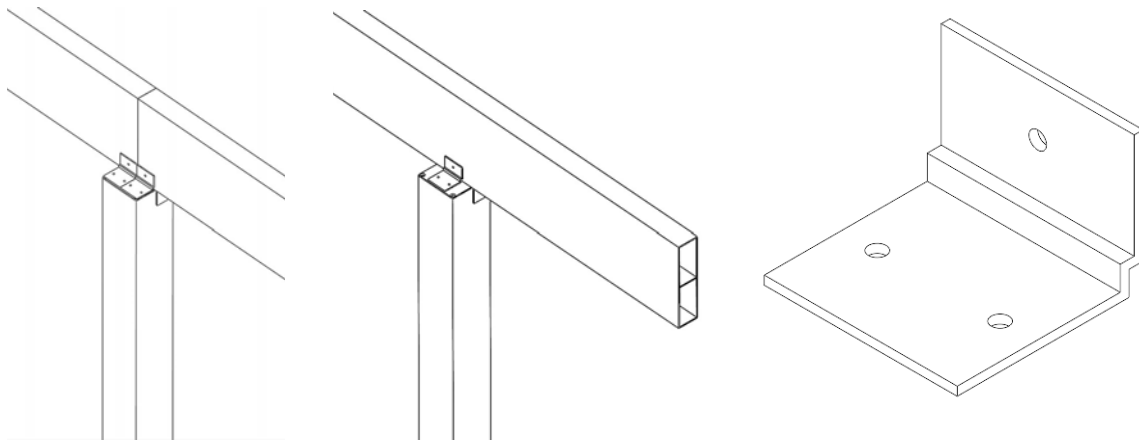

Post and Beam Installation (continued)

STEP 7

Ledger Installation

The ledger should be installed so that the **bottom** of the ledger is level and in the same plane as the **top** of the drop beam. If your design calls for the frame to slope away from the house, raise the ledger so that the bottom sits slightly higher than the top of the beam.

If installing a flush beam, the **top** of the ledger will be level with the **top** of the beam, unless a slope is required. You must predrill the ledger prior to installing LedgerLOK fasteners. Predrill through both walls of the ledger with a 5/16" or 3/8" drill bit, using the v-notches for vertical alignment. Alternate screws every 8" (or specified distance between the screws), placing one high and one low across the ledger in a "W" pattern. Refer to local building code for proper spacing and placement of anchor screws.

In some instances, LedgerLOK fasteners must be installed in pairs every 8" instead of a high/low "W" pattern. A registered design professional shall determine anchorage to wood ledger for designs not covered by Table 6 of CCRR-0523. A registered design professional shall also determine anchorage to wood ledger for anchors other than LedgerLOK anchors.

You must install a waterproofing membrane between the ledger and the house rim board. After the frame is installed, install an additional waterproofing membrane running from the house (behind any siding) and across the top of the ledger so that all water drains in front of the aluminum ledger. **See illustrations for this step on the next page.**

Disclaimer: This installation guide covers best practices for TimberTech AF deck frame assembly. Attachments to a house, building, structure, or foundation must be reviewed and approved by an engineer or architect. You must consult local building codes for specific project requirements.

Post and Beam Installation (continued)

STEP 7

Ledger Installation

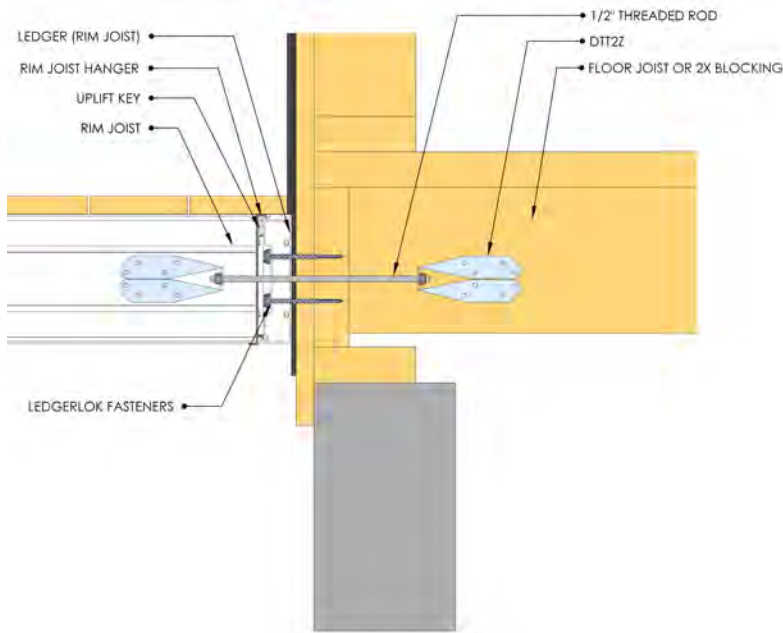

LEDGER CONNECTION DETAIL (THE LATERAL TENSION DEVICE)

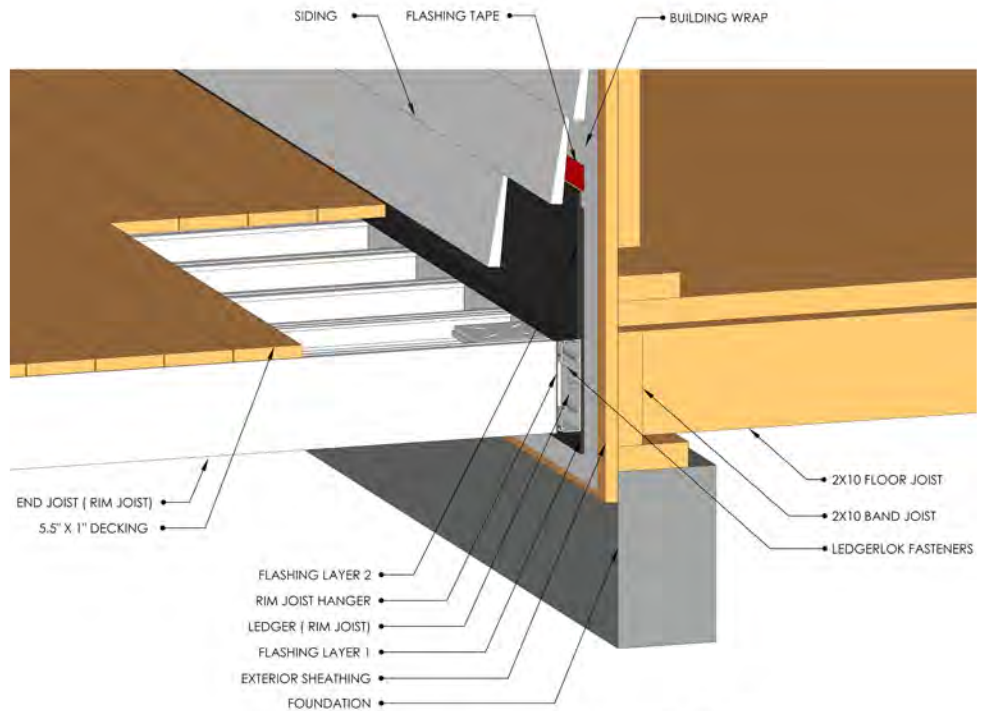
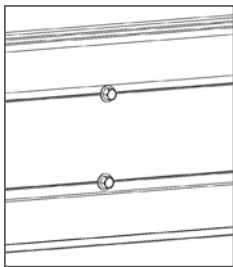

LEDGER CONNECTION DETAILS

Joist Installation

Joist Preparation

- A standard rectangular deck frame requires four Rim Joists components to form the perimeter. The 'ledger' and 'rim joist' are usually cut to the overall frame width. The two 'end joists' are cut to the same length as the Field Joists. The length of the field joists/end joists is determined by taking the overall frame length and subtracting 4 inches. (2" for the 'ledger' and 2" for the 'rim joist').
- Install rim joist hangers to every 'end joist' and field joist hangers to every field joist, using a joist hanger and two screws at each joist end. Screws must thread into the two internal screw chases on each end of the joist.

Parts required:

- (x) Rim Joists
- (y) Field Joists
- (2x) Rim Joist hangers
- (2y) Field Joist Hangers
- (4x + 4y) 1/4-20 hex head screws

FIELD JOIST

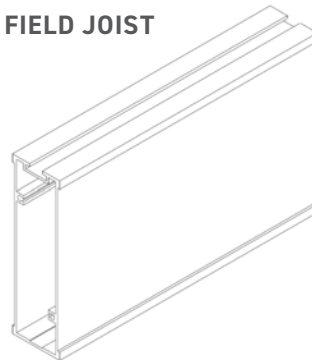

RIM JOIST

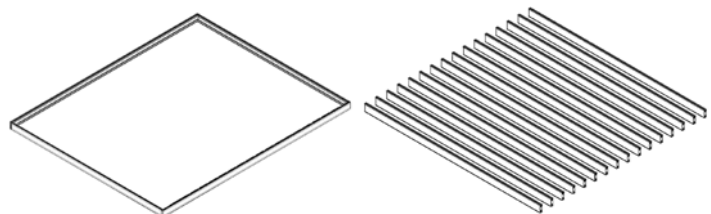
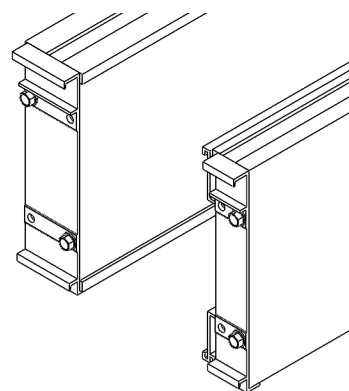
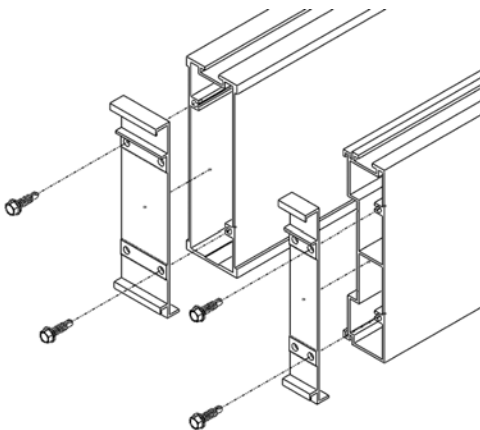
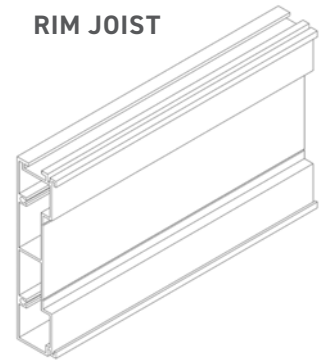

Ledger/Rim Joist Installation

STEP 8

Install rim joist corner templates on the ends of the ledger and rim joist using two 1/4-20 Flat head screws. The corner templates can be removed or left in place after the installation is complete.

Parts required:

- Ledger/Rim Joist
- Rim Joist Corner Templates (one for each corner)
- 1/4-20 x 1" flathead screws

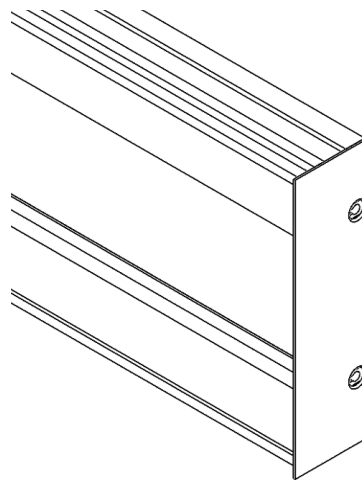

Field Joist Installation

STEP 10

Hang a field joist between the ledger and rim joist, approximately 12 or 16 inches from the end joist.

Parts required:

- Field Joist
- Field Joist Hangers
- 1/4-20 x 1" hex screws

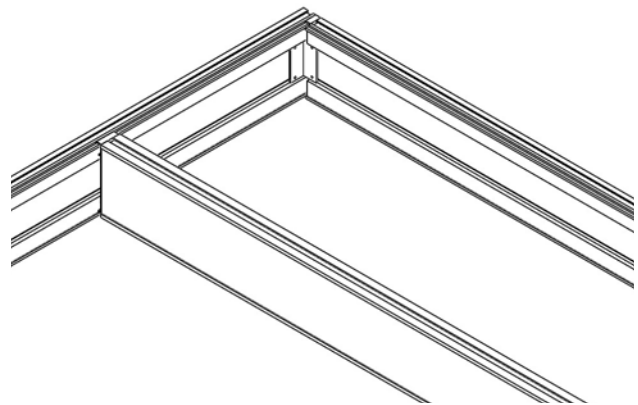
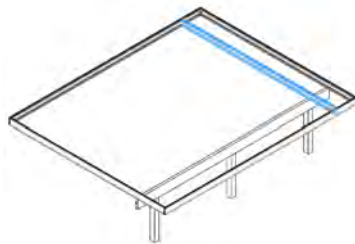

STEP 11

Hang a joist spacer on the rim joist to set the appropriate joist spacing, then insert a 2" Uplift Key through the top opening of the joist hanger. This locks the components to the rim joist and prevents the field joist or joist spacer from lifting up. It is critical to install a Joist Spacer on both sides of every joist to lock the uplift keys and prevent the joists from sliding along the rim joist track. Joist Spacers may be stacked (combined) or cut to smaller widths if the joist spacing is not standard 12" or 16" over center.

For 12" on-center, use 10" joist spacers.

For 16" on-center, use 14" joist spacers.

Parts required:

- Joist Spacer
- 2" Uplift Key

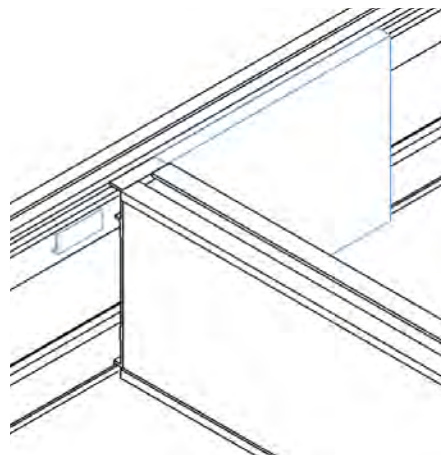

Field Joist Installation (continued)

STEP 12

Repeat Steps 10 and 11, installing Field Joists, Uplift Keys, and Joist Spacers, until there is one joist remaining.

An alternate method of installing joists is to use a Tall L-Bracket and four ¼-20 Hex head screws. This method does not require joist spacers and uplift keys.

Parts required:

- Field Joists
- Field Joist Hangers
- Joist Spacers (12" or 16")
- 2" Uplift Keys

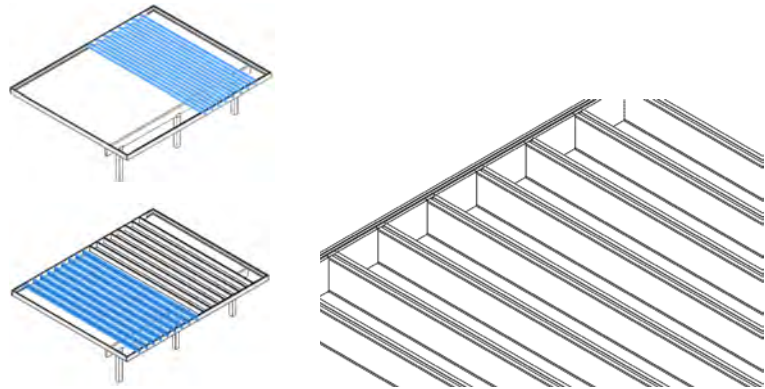

STEP 13

Install the last field joist and insert an uplift key. Then, measure the resulting gap between the outside rim joist and field joist and cut a spacer to the appropriate length. Alternatively, you can use a tall L-bracket or short L-bracket to secure the last joist. This method does not require a spacer and uplift key.

Parts required:

- Joist Spacers (12" or 16")
- 2" Uplift Keys

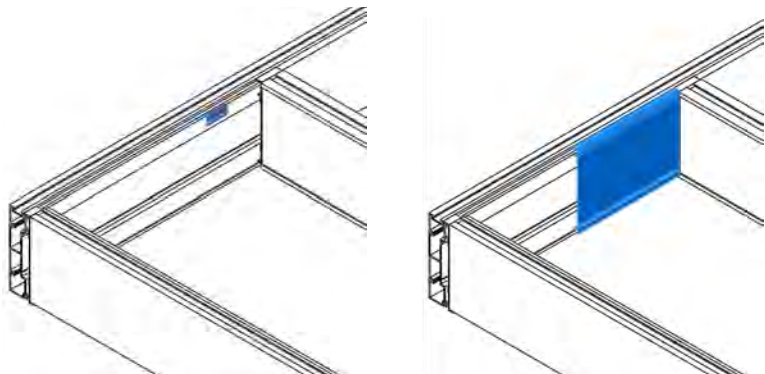

Joist Installation (continued)

STEP 14

At every joist to beam connection, install a Post/Joist to Beam Clip using three 1/4-20 Hex head screws. The bottom lip of the field joist should fit snugly under the step on the Beam Clip.

Parts required:

- Post/Joist to Beam Clips
- 1/4-20 x 1.25" hex head screws

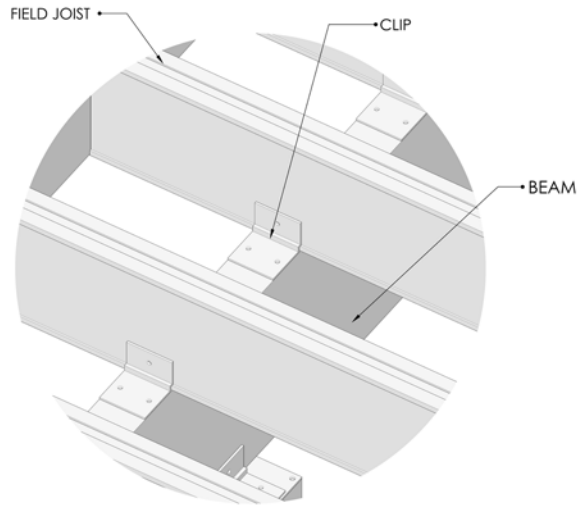

FIELD JOIST TO BEAM CLIP
SCALE 1:4

STEP 15

The open rim joist ends can be covered with a rim joist corner template, rim joist end cover, or fascia board.

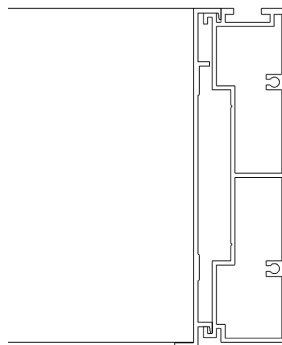

RIM JOIST CORNER TEMPLATE

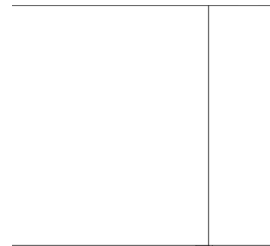

RIM JOIST END COVER

Field Joist Installation (continued)

STEP 16

The open beam ends can be covered with a Beam Cover using adhesive caulk (black is recommended).



Decking Installation

Storage/Handling/Cutting

- Keep the deck boards cool as possible and out of direct sun until fastened down. Pictured is a white tent canopy to cover storage and cut area.
 - For best results, It is critical that the **decking be attached under shaded conditions or out of direct sun light** to best reduce gapping and contraction of the material.
- Store the deck boards FLAT and keep clean and shaded during installation.
- **Avoid Dragging or Sliding Boards over one-another—always ‘Lift and Carry’**
***Sliding can cause Surface damage, marring and scuffing.**
- Cut the deck boards using a 12” Miter Saw Equipped with a 100 carbide teeth, fine finish blade with a thin kerf.
- Cut boards one at a time with the walking surface / textured side ‘UP’.
- Cut and install / fasten each board before moving on, do not cut a bunch of boards ahead of time, then try to fasten.



Decking stored flat and in shade—out of direct sun.

12" Compound Miter saw and stand.



12" x 100 teeth blade type



Decking Installation (continued)

Starter Board and Spacing

- Start the first board straight, using a string line, laser, or other method of ensuring a straight starter deck board.
- Use 1/8" spacers between deck boards, often, to ensure an 'even' 1/8" spacing between deck boards.
- Check every 3 to 4 rows as you go to ensure 'straight', or make any adjustments if boards are not completely straight.
- Fasten down the entire board before moving on to the next board.
- Always keep boards as cool as possible until fully fastened.



For best results, keep deck boards cool as possible until completely fastened down – shade the surface, install on cloudy days, earlier morning or later afternoon when sun angle is lower—for some examples.

Decking Installation (continued)

Starter Board and Spacing (continued)

- For best results, fasten using a 20v Impact Driver equipped with the correct Cortex Driver Bit (comes with the Cortex Driller Screws).
- May need to change the driver bit if the Felt Pad becomes worn or damaged—as this can affect the ‘setting depth’ of screw.
- **IMPORTANT:** Drive the Cortex Screws ‘Straight Down’—**Do Not Angle or try to drive the screws at an angle.**
- When Driving the Cortex, Insert the driver bit into screw and place the screw on the deck board where intending to fasten, **then using constant downward FORCE on the driver** pull the trigger and drive the screw straight down—**Do Not Let off the Trigger.**
- Stand on the board/or clamp tight to joist when fastening—to ensure tight contact of bottom of board to joist before fastening.
- **The Cortex Screw will automatically ‘release from the driver’** once it reaches the correct countersink depth—you will hear and feel the screw release—maybe practice on some scrap to get the feel.
- *There should be no need to pre-drill—either the deck board or the aluminum frame (With the exception of Butt-joints and Miter Joints.)
- However, in the rare case it is needed, a **5/32” drill bit can be used**—drill through both the deck board and aluminum frame—then drive the Cortex Driller. See next page for pre-drill.



Using constant downward pressure – drive screw straight down until screw releases from bit.

Decking Installation (continued)

Pre-Drilling at Butt-Joints and Miter Joints

- At Butt-joints and Miter Joints, the screw locations should be pre-drilled using a **5/32" drill bit**.
- This pre-drill helps to keep the two deck boards at the same 'height' on the frame and eliminates the metal chip build up under the board ends. At these joints there can be an un-even chip build under the boards from the metal frame causing the deck boards to show an un-even top edge.
- Butt-joints and Miter Joints are always pushed together tightly, do not leave a gap between the boards at these locations.
- Stand on top of the boards, or clamp tightly to the joist during fastening, to ensure full contact of deck board to joist.
- Always install the boards as cool as possible and out of direct sun until fully fastened down.
- See Next Slide couple slides for Fastener Positioning and Locations.



Pre-Drilling at Butt-Joints and Miter Joints— 5/32" drill bit, pre-drill at joints

Decking Installation (continued)

Fastener Locations and Positioning

- Keeping boards cool as possible and out of direct sun—fasten per the installation guidelines.
- Proper screw location is important and must be followed for best results.
- Within 1/2" of all board ends, butt-joints, and miters.
- 3/4" off side edges.
- 2 screws every joist location not to exceed 16" OC Max.
- Completely fasten down each board as you go.

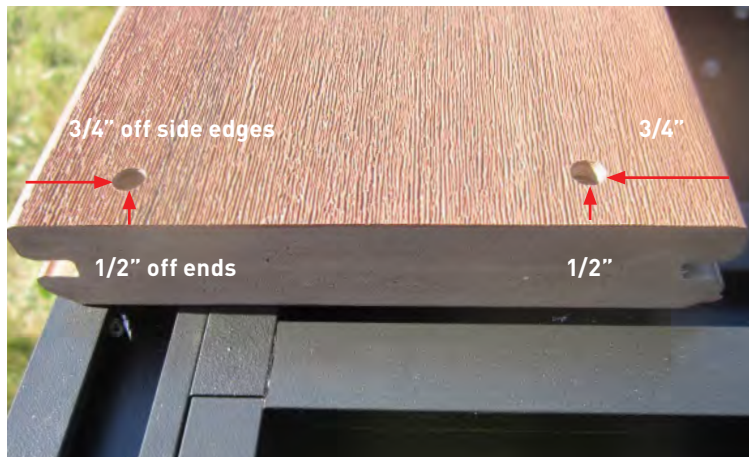

Within 1/2" of ends, along miters, and butt-joints

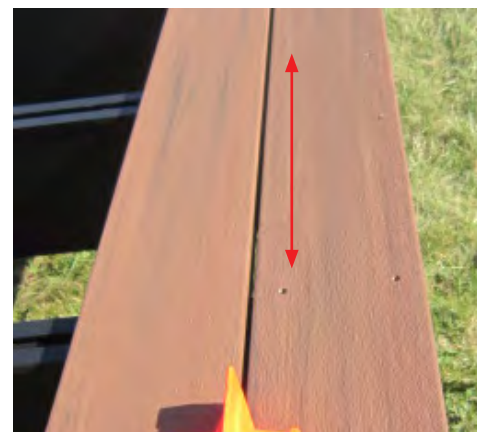
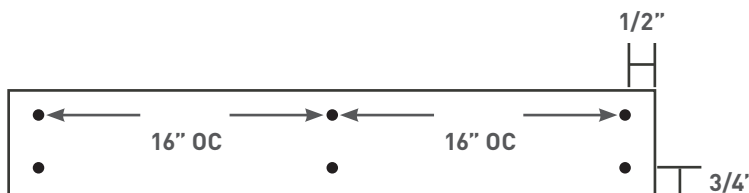

2 screws every joist location – 16" OC Maximum distance

Decking Installation (continued)

Screw Fastening on Aluminum Joists – Flat Areas

- If the Aluminum Joist shows having the deep ‘Clip Groove’ in the middle of the extrusion, position the Cortex Driller screws just off the center, on the flat areas of the joists – as seen below.
- You can screw fasten close to this groove without issue – however, if the screw is driven too closely and along the side edge or in the middle, it could cause screw to lean, kick, and not be driven straight down – aim for flat top part of joists – as seen below.

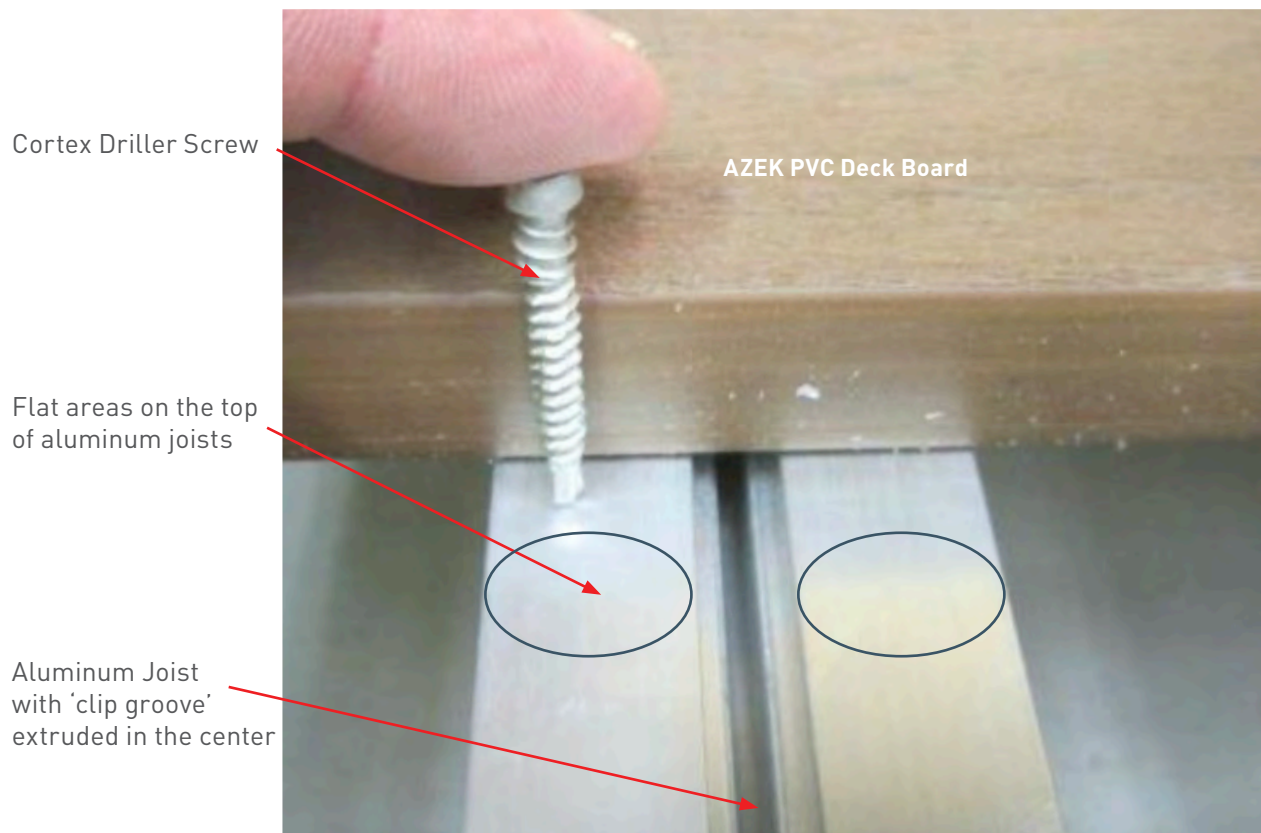

Decking Installation (continued)

Un-Even Butt-Joints and Miter Joints – Joist Tape Shim

- It can be possible for a slight 'height difference' where boards come together, whether it is debris under board or tolerances.
- Joist tape can be used as a 'shim' to help bring the two board surfaces back into 'plane' and the same flush height.
- This can work with butt-joints and miter joints.
- *Always check board heights at joints prior to fastening, to ensure a smooth even flush surface.

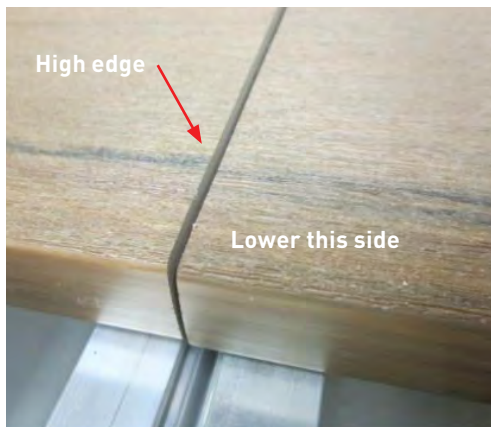

Un-even butt-joint, one board slightly higher than the other.

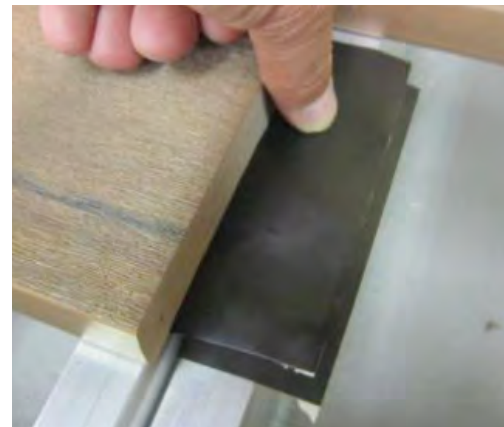

Install appropriate layers of joist tape to shim up the low side.



Self adhering TimberTech Pro-Tac Joist tape.



After Joist Tape , joint shows an even flush surface , then fasten down.

Decking Installation

Installing the Plugs – After Fastening

- The countersunk holes must be free of debris and moisture to ensure a proper plug fit/ function.
- Plugging the holes soon after the fastening may help prevent job site debris from getting into the holes.
- Plugs should finish out 'FLUSH' with the deck surface.
- If Plugs are not finishing out flush or too high, check the felt on the driver bit and ensure that the Cortex Screws are being driven to the proper depth.
- Use a hard Plastic Mallet to set the plugs – a metal hammer can cause damage to surface.
- If working on hands and knees to install plugs, avoid dragging soles and toes of shoes/boots across the deck surface – recommend boot coverings or socks, or other non-marking footwear or blankets. Some shoes and boot soles can cause very stubborn 'Marring and Scuffing.'



The Cortex screw will bore the correct size hole for plug.

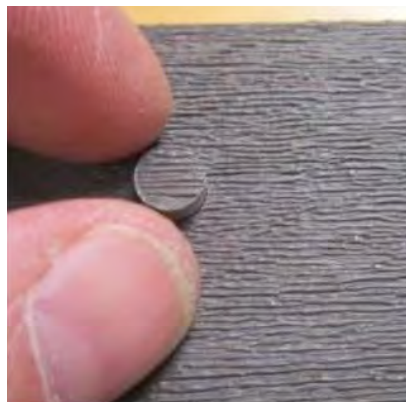

Align the 'grain direction' of the plug and push into hole.



Tap plug 'flush' using a PLASTIC Mallet.

Other Considerations



WARNING: DO NOT USE THE FINISHED DECK SURFACE AS A 'WORK AREA'.

- If there is other work or construction to be done around or near the deck, strongly suggest completing those jobs **FIRST**, before installing the deck boards. A temporary work area of Plywood or other could be placed on the framing to serve as a work area (Before the finished deck is installed for example).
- Avoid building or constructing other items on finished deck surface, such as railing systems, planter boxes, etc. Strongly recommend building and constructing other items off of the finished deck and deck boards.
- Do Not Build Walls directly on the deck boards – best to install decking up to walls and other partitions. If a deck board needs replaced in the future, it is accessible to and the weight of some walls on the decking can cause issues.
- Avoid Dragging or Sliding deck boards over one-another, always lift and carry to place boards.
- Avoid Dragging or Sliding tools or any other hard / sharp objects over the deck surface.
- When working on hands and knees, protect the deck, some knee pads and shoe/boot soles can cause very stubborn scuffs and mars – possible cardboard or soft cloths could be used for example. Work with boot coverings or similar. Always check to see if scuffing is being created.

Rail Post Installation

All TimberTech Railing Systems can be surface mounted to a TimberTech frame. The pre-drilled bolt hole patterns will accept a 2" or 3" Impression Rail post, a 2" or 3" Impression Rail Express post, or Secure Mount Posts.

Parts required:

- Rail Post L-Bracket
- 1/4-20 x 1" hex screws
- Railing Post

Rail Post L-brackets can be attached to a corner blocking member or to an end joist with a supporting blocking member.

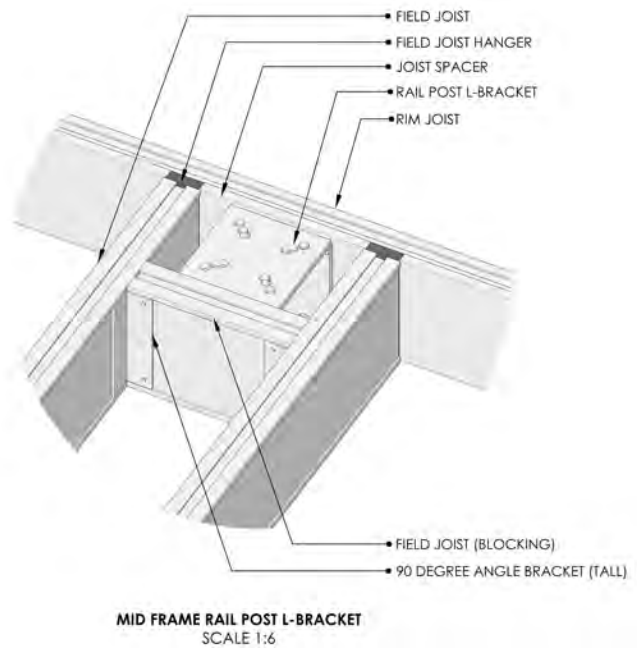
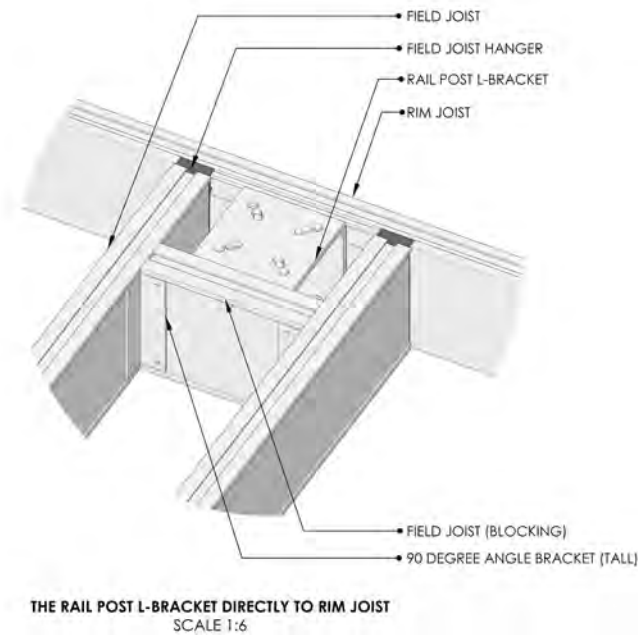

Rail Post Installation (continued)

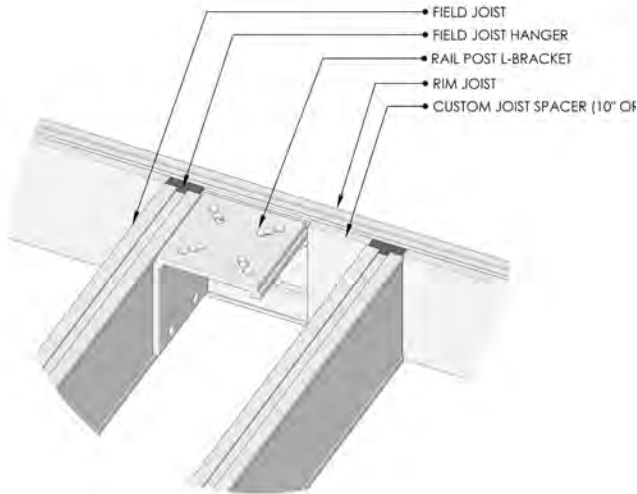

THE RAIL POST L-BRACKET TO FIELD JOIST
SCALE 1:6

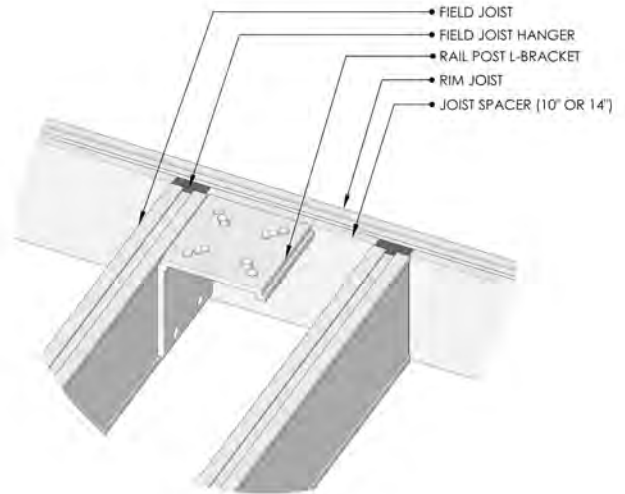

THE RAIL POST L-BRACKET DIRECTLY TO AN ADJACENT FIELD JOIST
SCALE 1:6

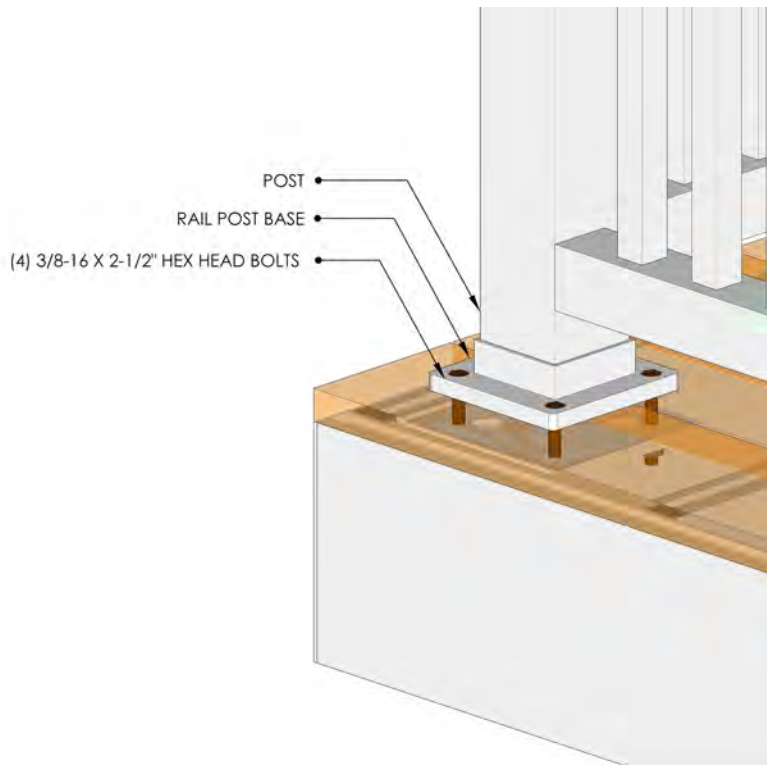

SURFACE MOUNTED RAIL POST CONNECTION DETAIL

Rail Post Installation (continued)

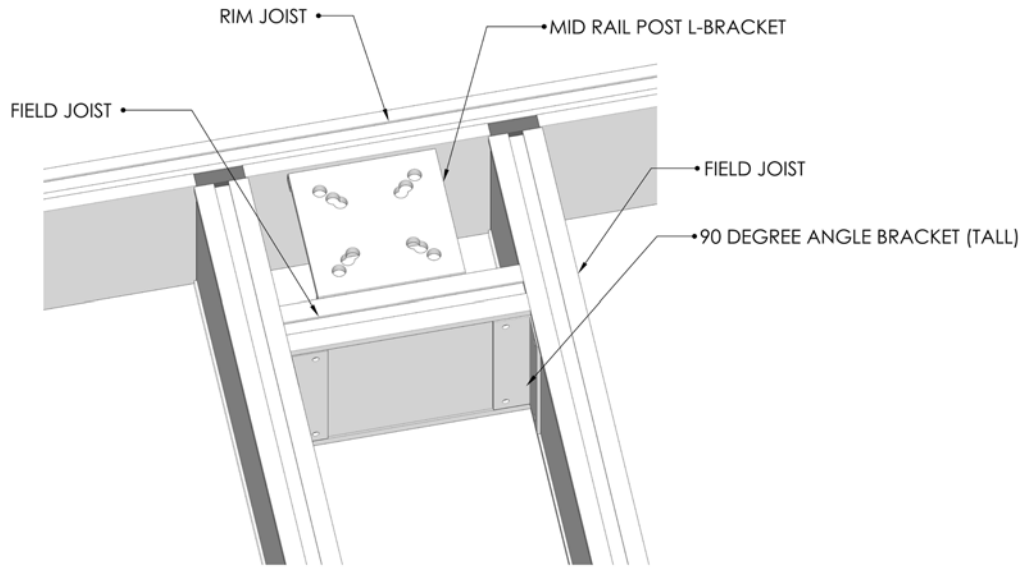

MID DECK
SCALE 1:4

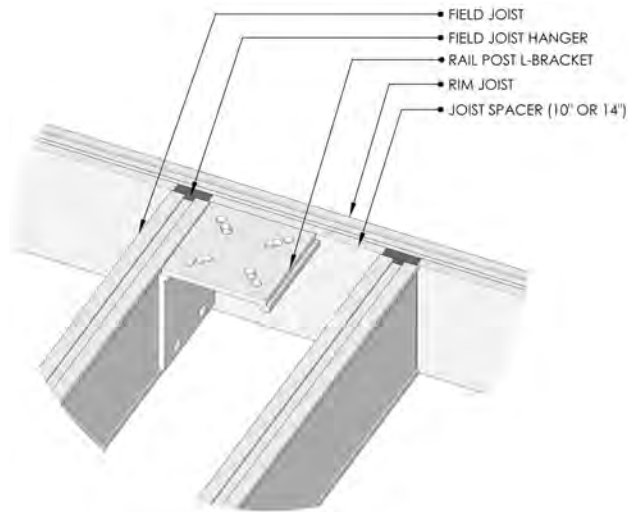

THE RAIL POST L-BRACKET DIRECTLY TO AN ADJACENT FIELD JOIST
SCALE 1:6

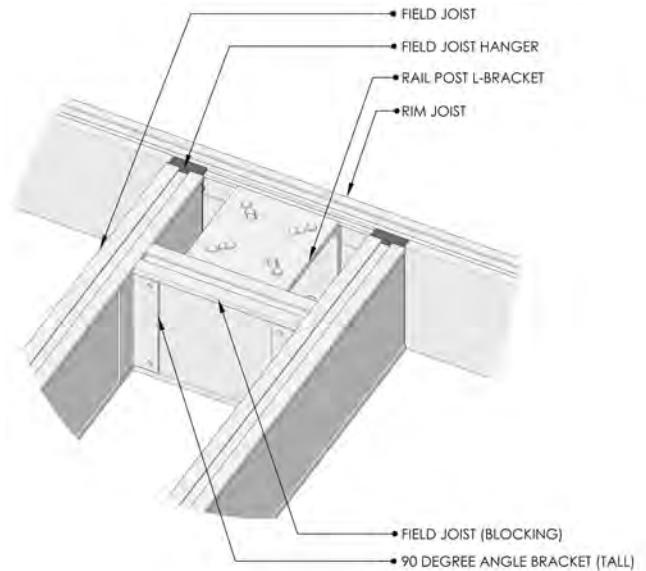

THE RAIL POST L-BRACKET DIRECTLY TO RIM JOIST
SCALE 1:6

Rail Post Installation (continued)

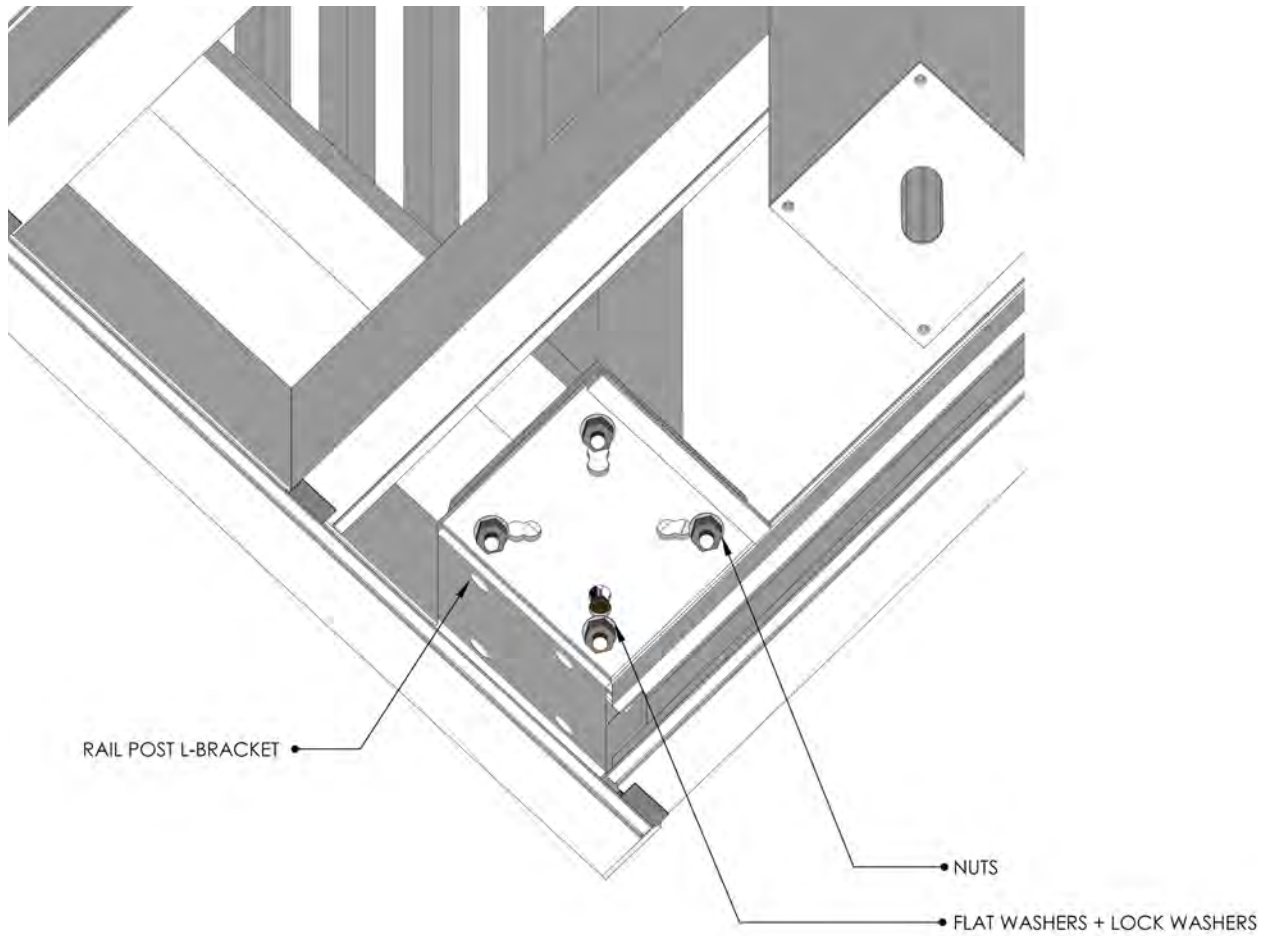

UNDERSIDE OF SURFACE MOUNTED RAIL POST CONNECTION DETAIL

Rail Post Installation (continued)

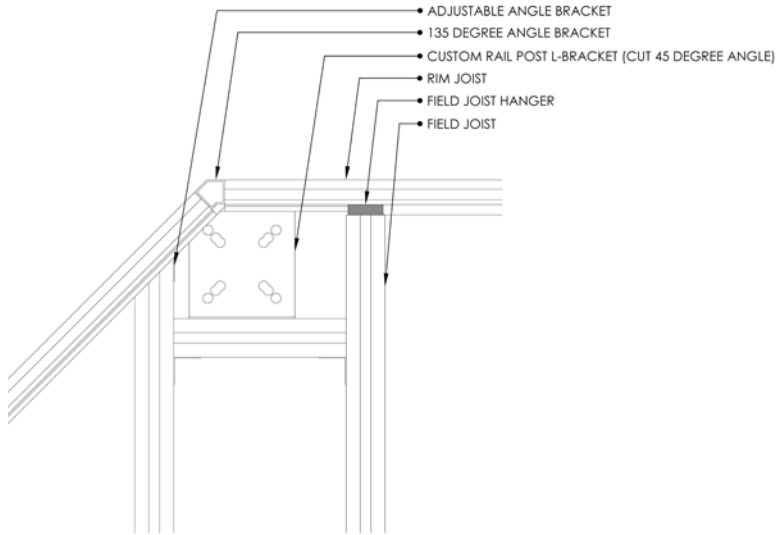

135 DEGREE ANGLE BRACKET & CUSTOM RAIL POST L-BRACKET

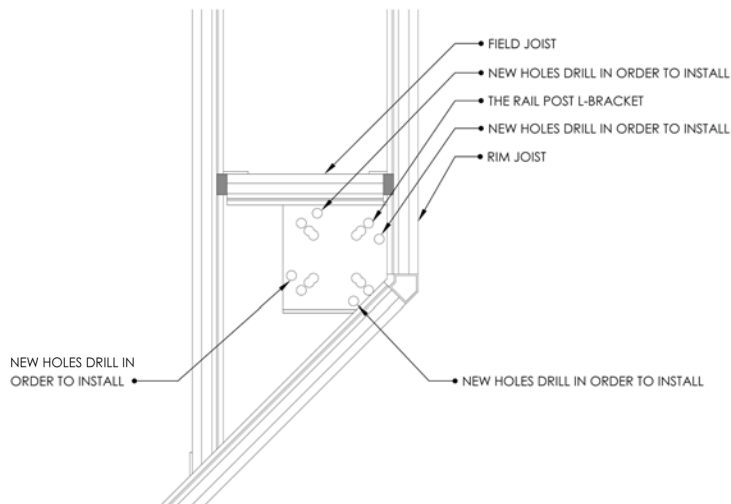

THE RAIL POST ATTACHMENT AT A 45 DEGREE ANGLE

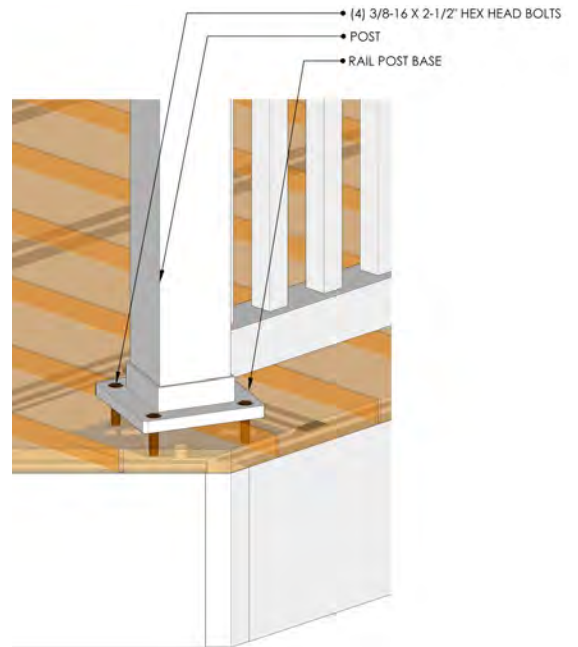

THE RAIL POST ATTACHMENT AT A 45 DEGREE ANGLE

Stair Installation

STEP 1

The Rim Joist component is also used as a stair stringer. Most first story residential stairs can be framed up to 10 steps (72.5" rise) with a single left and right stringer. To achieve a higher rise, as in a second story deck, you can double up each stair stringer, using fasteners to connect the two rim joists/stringers.

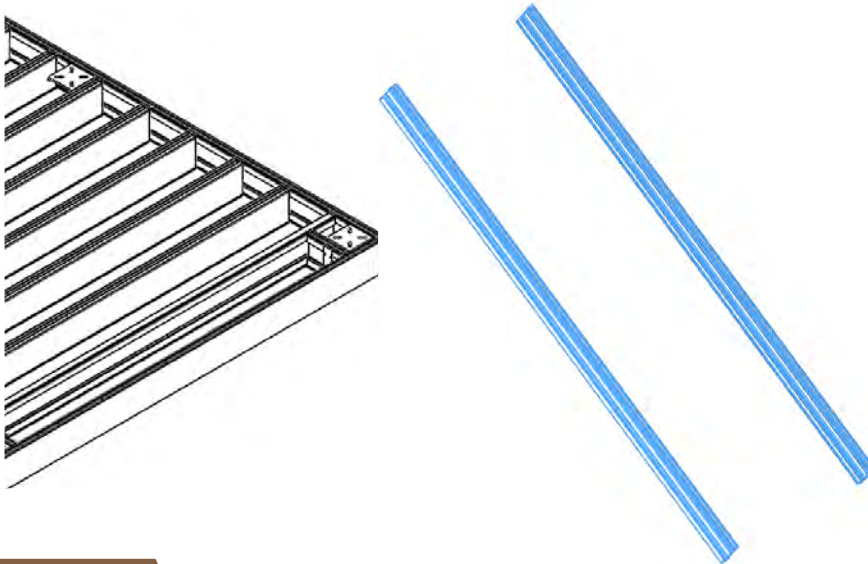

STEP 2

The stringers need to be cut down to rest flat against the rim joist of the deck on one side, and flat against the ground on the other. The stair angle is fixed at 34 degrees, so in some cases you will need to build up grade to reach the bottom of the last step.

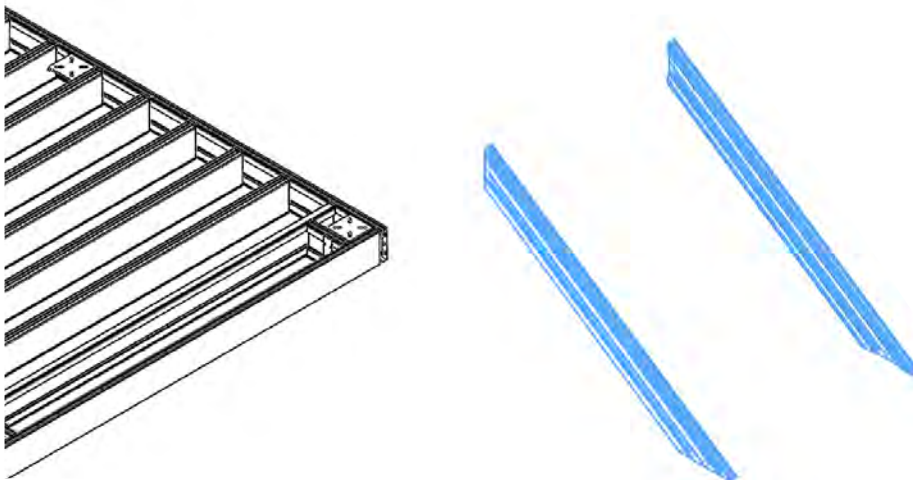

Stair Installation (continued)

STEP 3

As seen from another angle, the stringer has been cut as suggested. Please note that the stair system is designed around a 34° angle (this equates to a 7.25" rise over a 10.75" run).

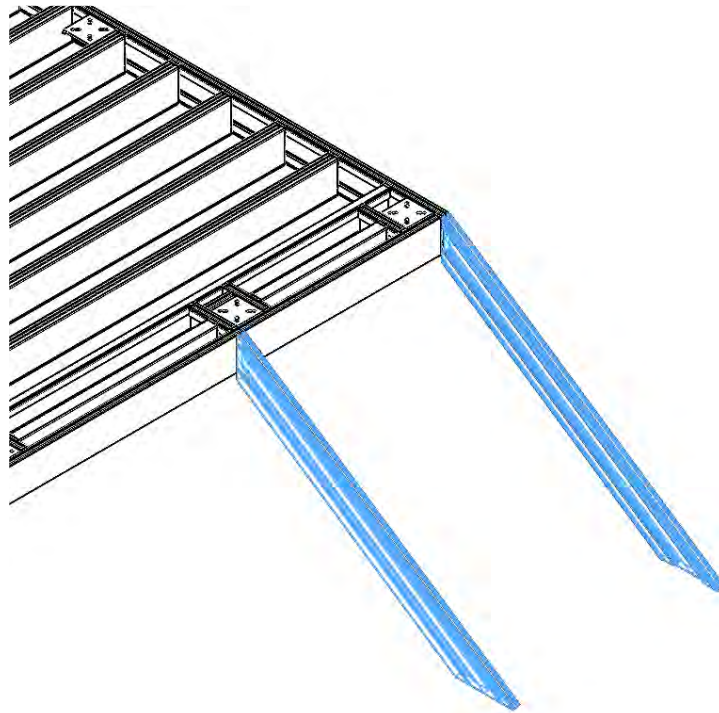
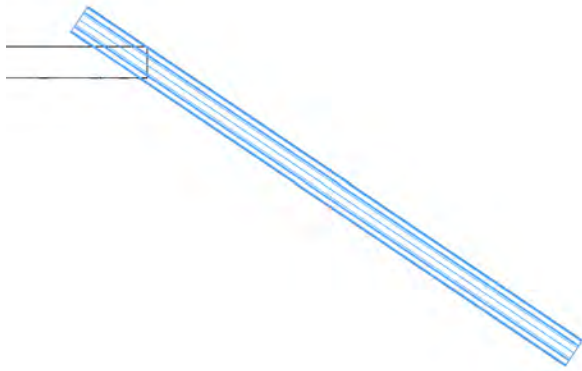

Stair Installation (continued)

STEP 4

Please note that the stair system is designed so that the stringers are 48" apart (measured from the outside edge of each stringer). Other widths can be accommodated, but such an assembly will require the use of a "Middle Stair Tread Bracket" and another stringer.

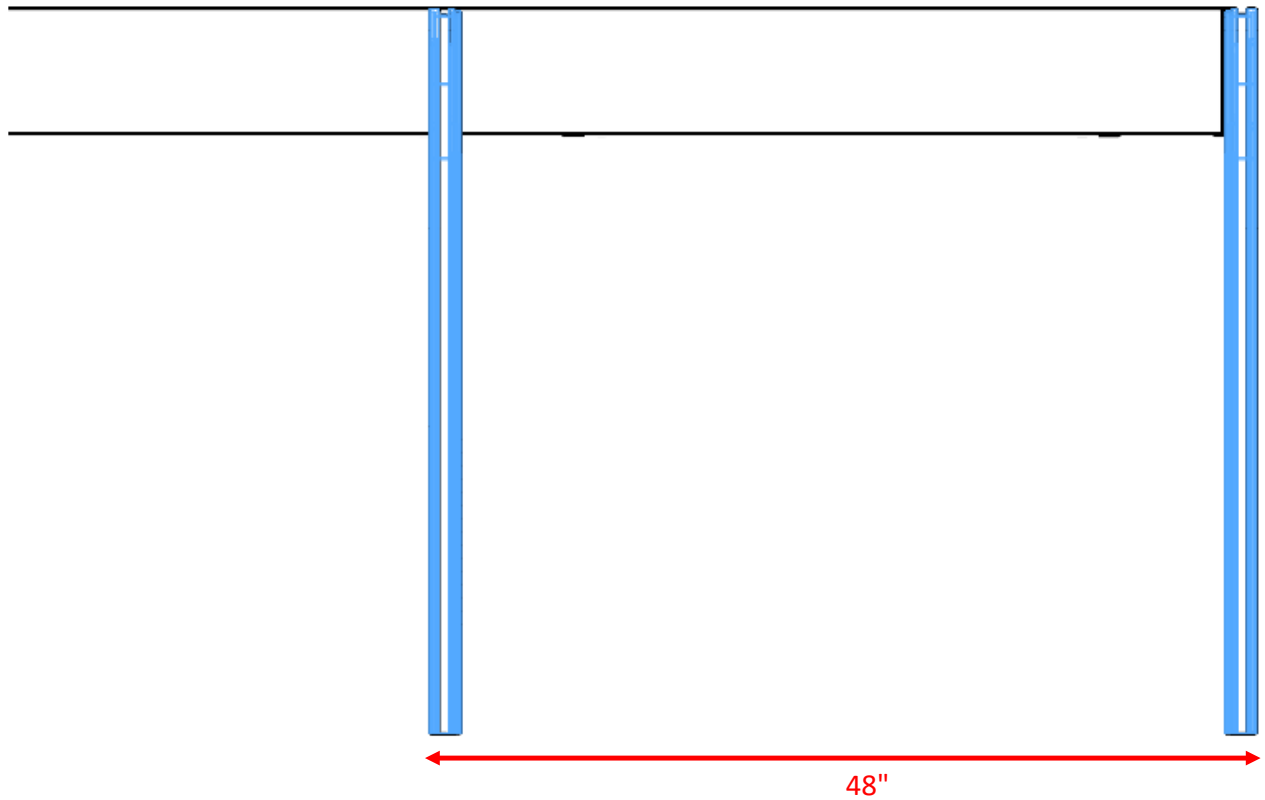

Stair Installation (continued)

STEP 5

The stringers are now ready to be attached to the deck frame landing and the foundation landing. Each corner requires a Stair Landing L-Bracket oriented in the correct direction.

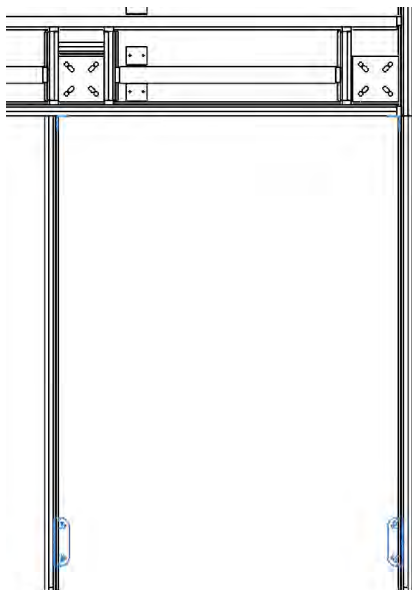
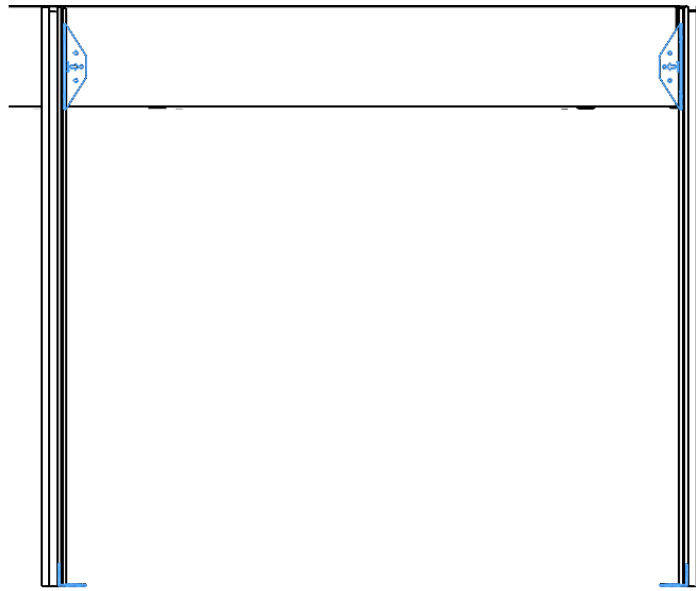

Stair Installation (continued)

STEP 6

The Stair Landing L-bracket fits within the stringer's cavity when used to attach to the foundation landing. Use three ¼-20 hex head screws into the stair stringer and three Tapcon anchors (or other fastener) into the foundation.

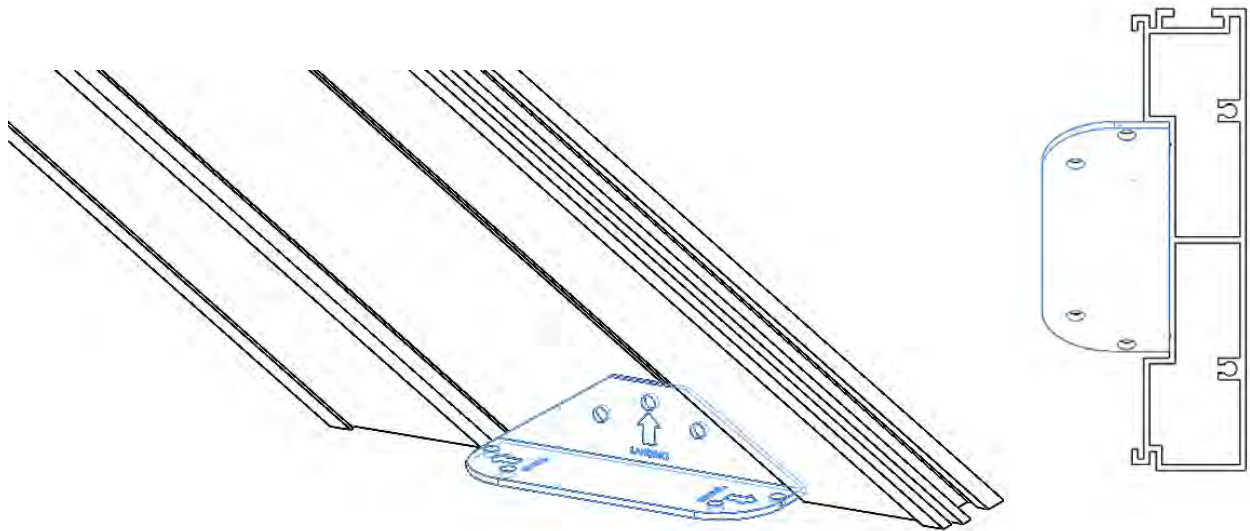

Stair Installation (continued)

STEP 7

To attach the right stair stringer to the deck frame, orient the Stair Landing L-Bracket so the "Top Right" arrow is snug against the "hook" of the stair stringer. Use three ¼-20 hex head screws to fasten to the stair stringer and three screws to fasten to the frame landing.

Repeat the process for the left-hand stringer, ensuring the "Top Left" arrow is snug against the top of the stringer.

There will be a gap between the Lbracket and the stringer cavity—a screw is not required in this hole.

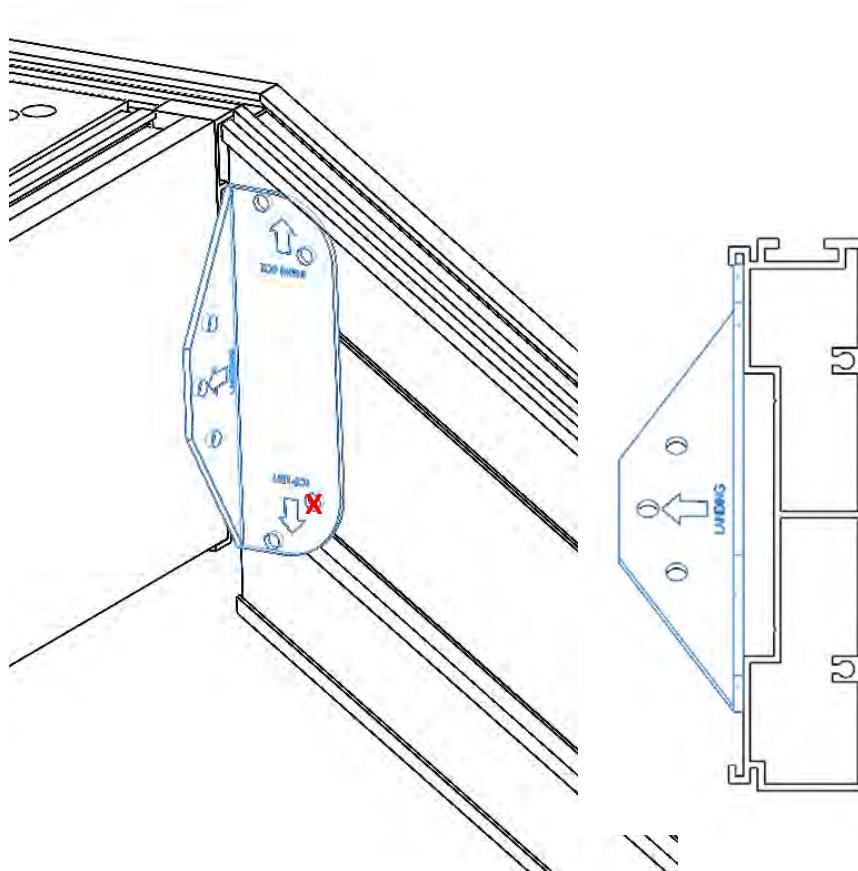

Stair Installation (continued)

STEP 8

There are arrows on the stair landing L-bracket to help orient it during installation. If the part is being used to attach the stairs to the foundation landing, the arrow next to the word “Landing” should be pointed upwards.

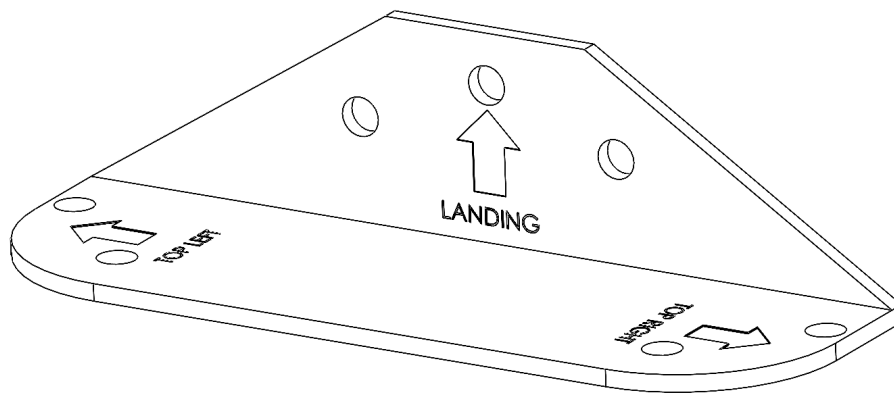

STEP 9

Likewise, if the clip is being used at the top right part of the stairs, to attach the stringer to the deck, the arrow next to the words “Top Right” should be pointed upwards.

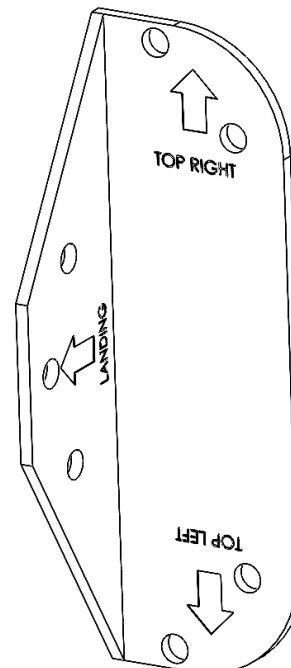

Stair Installation (continued)

STEP 10

Now that the stringers are installed, it is time to attach the “Stair Tread Brackets”. Please note that there is a Left and Right “Stair Tread Bracket.”

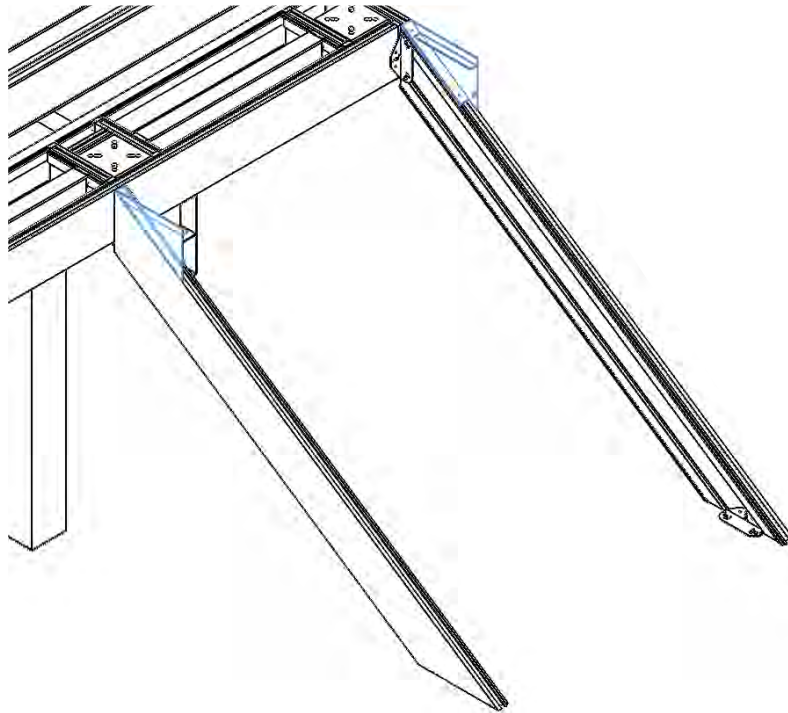

STEP 11

The left and right stair tread brackets should line up with the top of the deck substructure. This provides a first “step” that is flush with the rest of the deck.

Alternatively, a drop stop can be achieved by fastening the stair stringers to a pair of posts, a drop beam, or a 4ft suspended joist (securely fastened to frame or supported by posts).

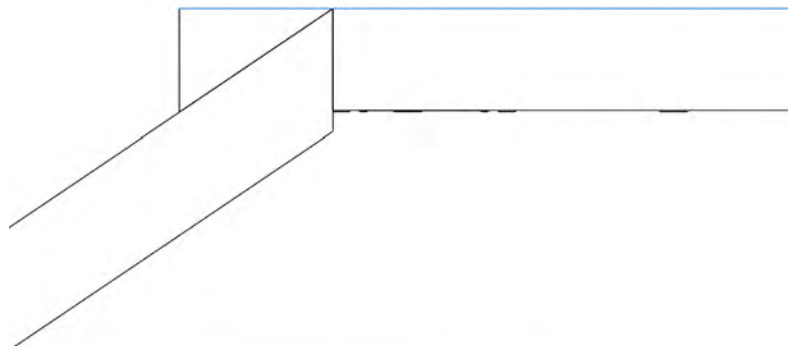

Stair Installation (continued)

STEP 12

Fasten the rest of the stair tread brackets. The brackets stack with each corner touching in order to provide proper spacing.

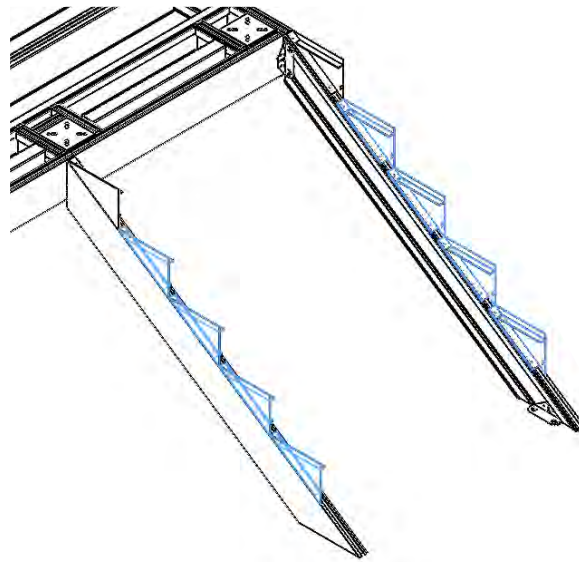

STEP 13

The “Front Stair Tread” can now be installed on the shelf provided by the riser caps.

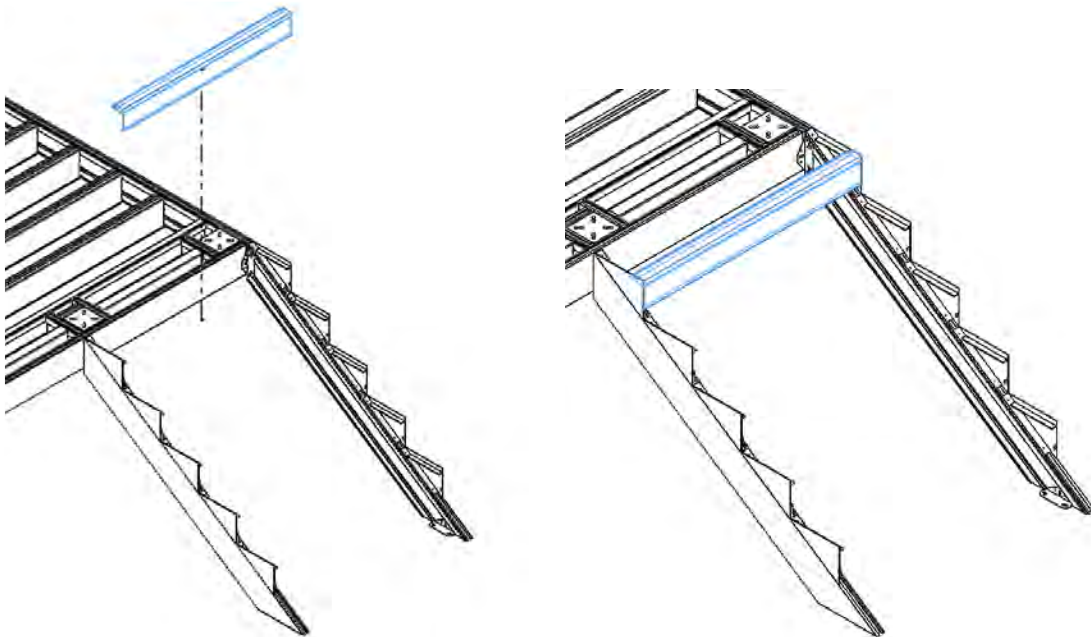

Stair Installation (continued)

STEP 14

Carefully push the Front Stair Tread onto the ledge provided by the Stair Tread Brackets.

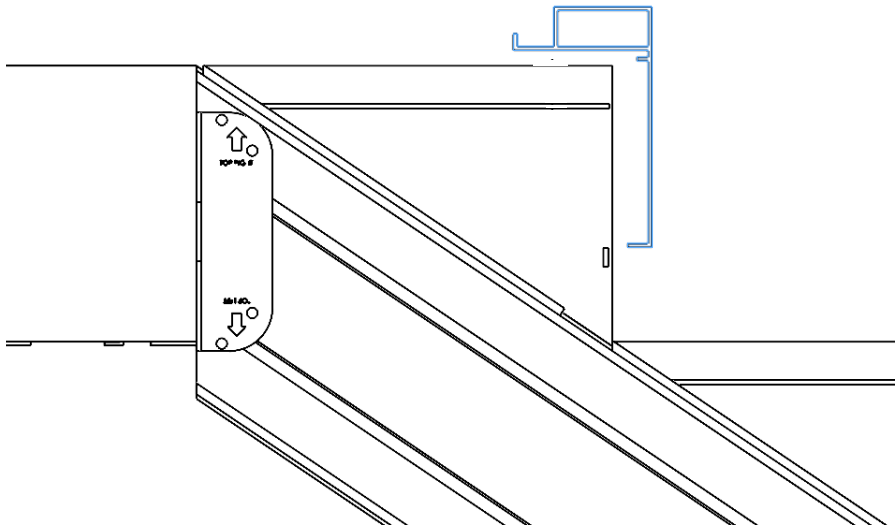

STEP 15

When installed correctly, the Front Stair Tread will be flush with the top and front edge of the Stair Tread Bracket.

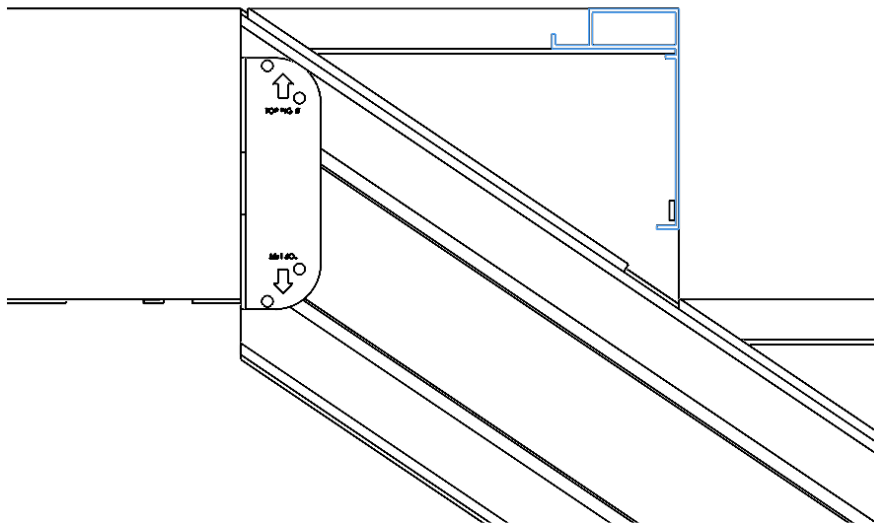

Stair Installation (continued)

STEP 16

Next, place the Back Stair Tread on the stair tread brackets so that it interlocks with the Front Stair Tread.

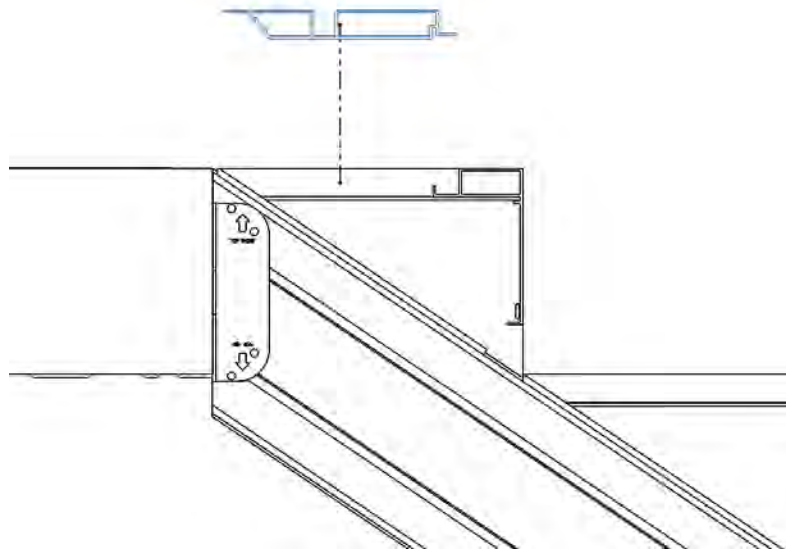

STEP 17

When properly installed, the entire stair tread will be flush with the top edge of the Left and Right Stair Tread Brackets. Use two ¼-20 hex head screws to fasten the Stair Tread to each Stair Tread Brackets.

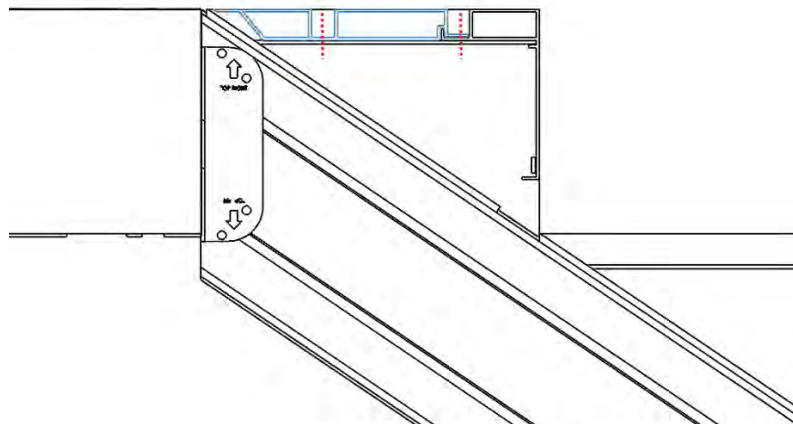

Stair Installation (continued)

STEP 18

Repeat this process for the rest of the stair trays. Each Stair Tread requires four 1/4-20 hex head screws.

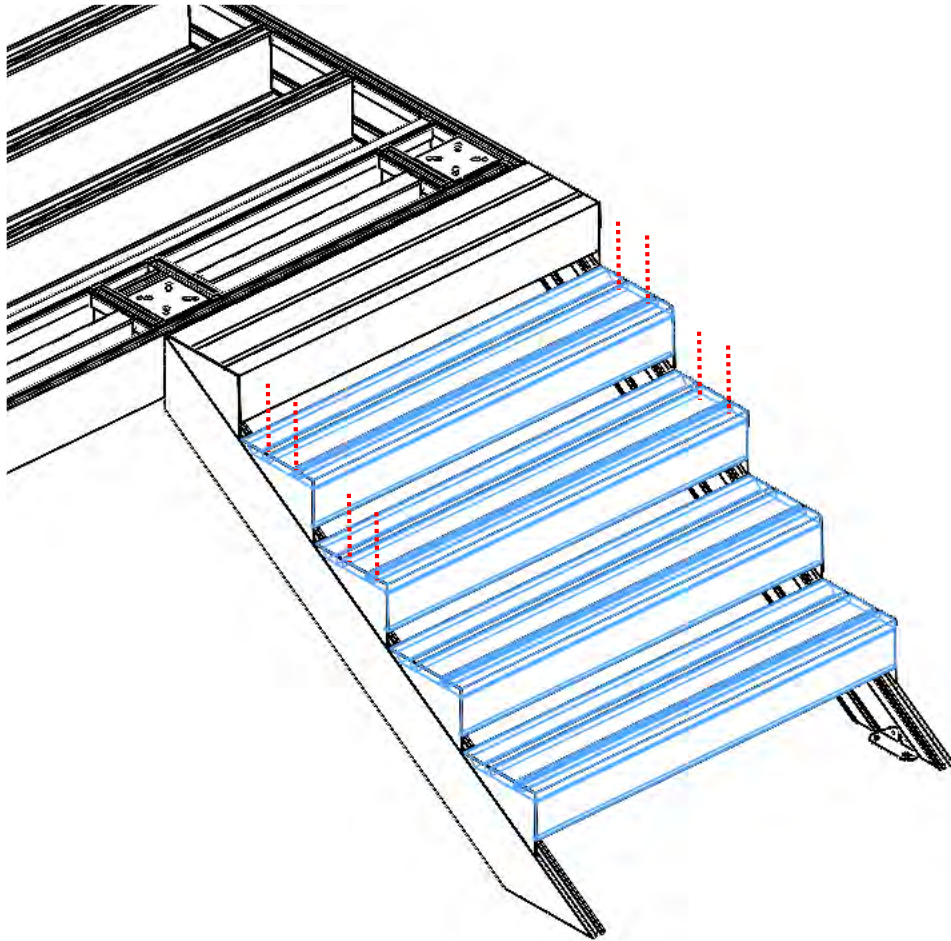

Stair Installation (continued)

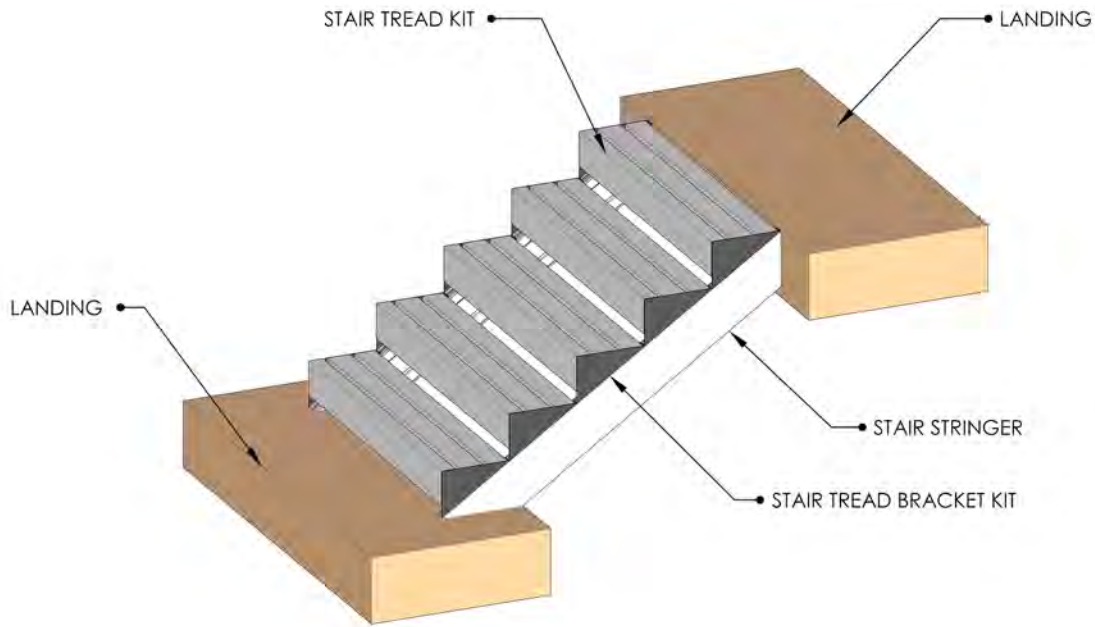

FLUSH STEP STAIR DETAILS
SCALE 1:24

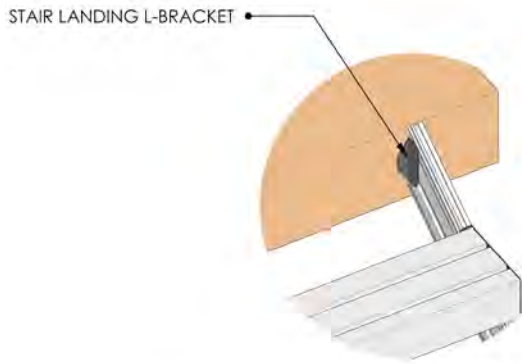

TYPICAL FLUSH STEP STAIR LANDING L-BRACKET (UP)

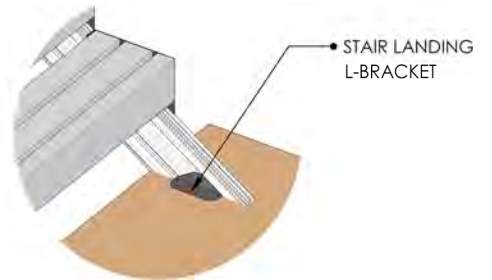

TYPICAL FLUSH STEP STAIR LANDING L-BRACKET (DOWN)

Stair Installation (continued)

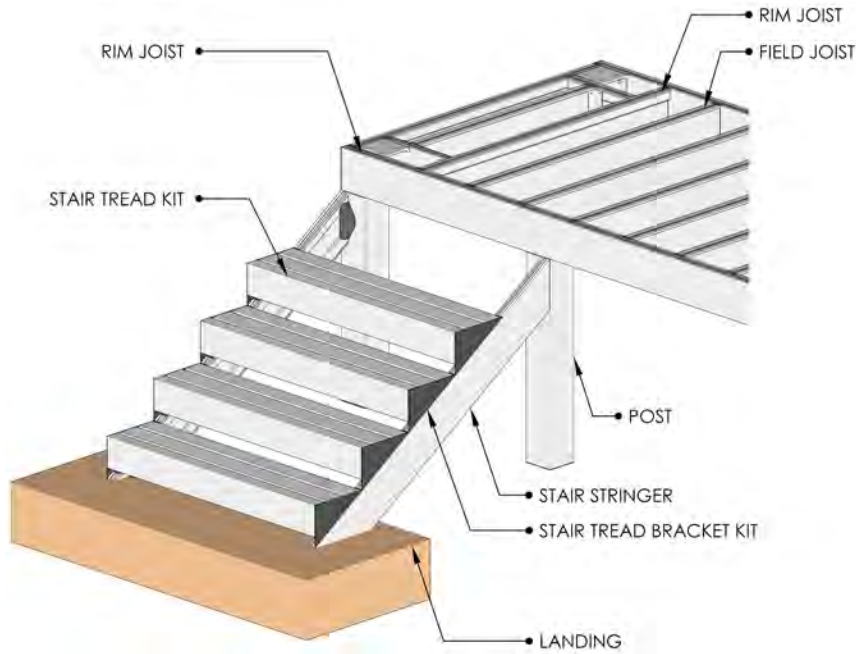

DROP STEP STAIR CONNECT TO POST DETAILS
SCALE 1:24

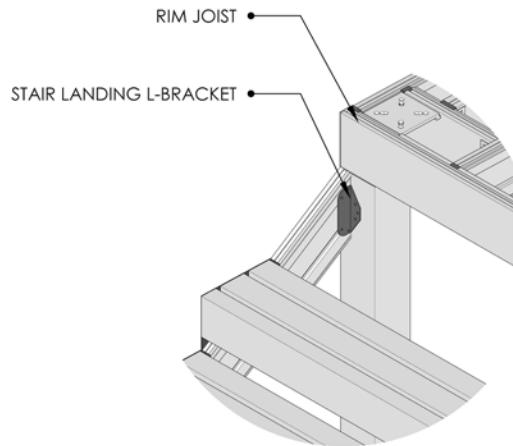

TYPICAL DROP STEP STAIR L-BRACKET CONNECT TO POST (UP)

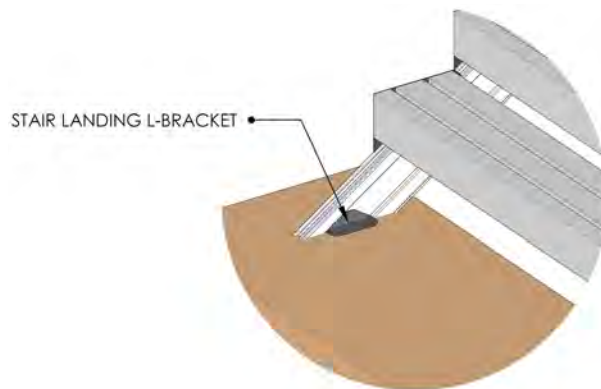

TYPICAL DROP STEP STAIR LANDING L-BRACKET (DOWN)

Stair Installation (continued)

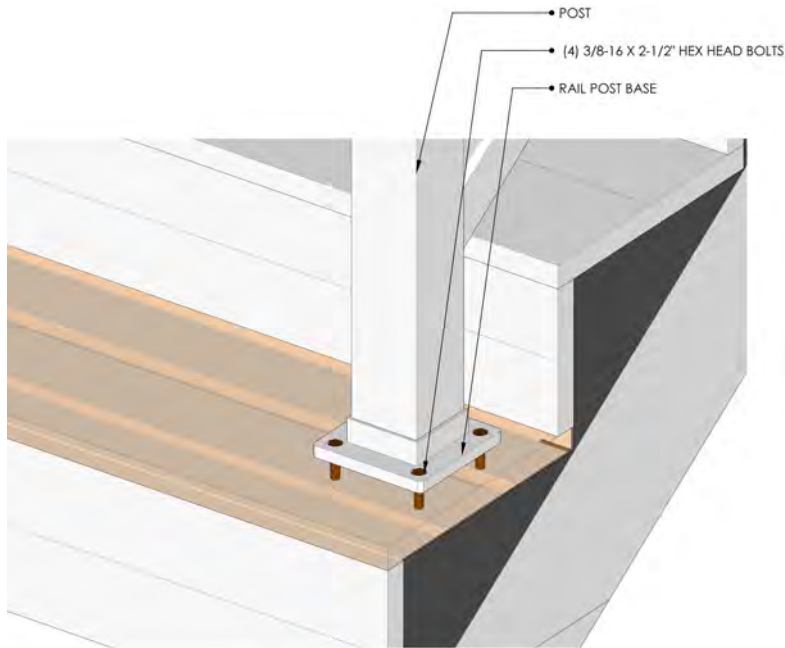

TOP SURFACE OF STAIR RAIL POST CONNECTION DETAIL

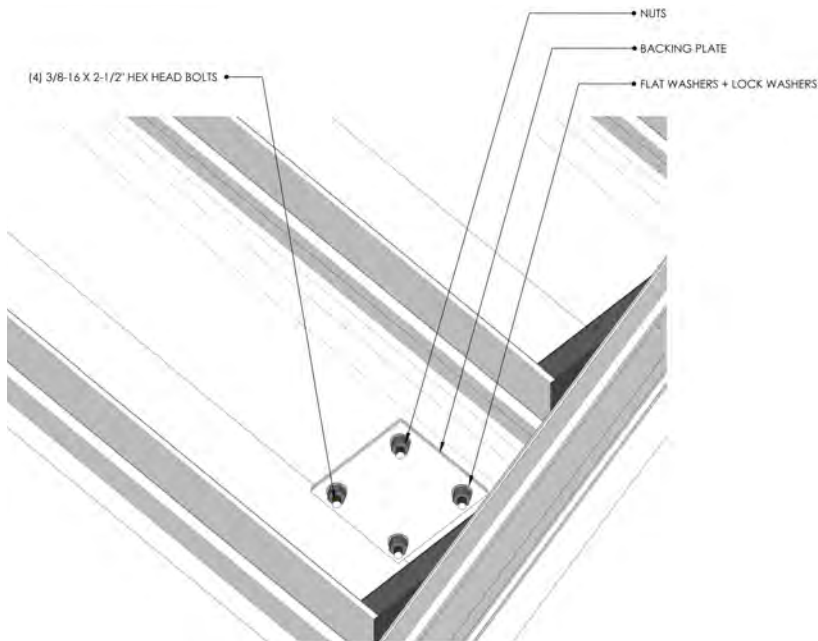

UNDERSIDE OF STAIR RAIL POST CONNECTION DETAIL

Additional Considerations

Picture Frame Borders and Midspan Blocking

Parts required:

- Rim Joist
- Field Joist
- Rim Joist Hangers
- Field Joist Hangers
- Short L-Brackets
- 1/4-20 x 1" hex screws

Joist Blocking can also be installed using Field Joist sections, Tall L-Brackets, and 1/4-20 Hex head screws.

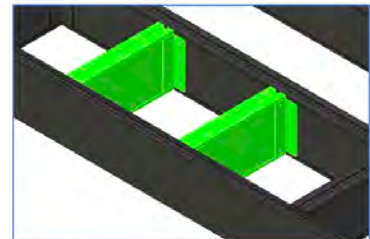

SINGLE PICTURE FRAME

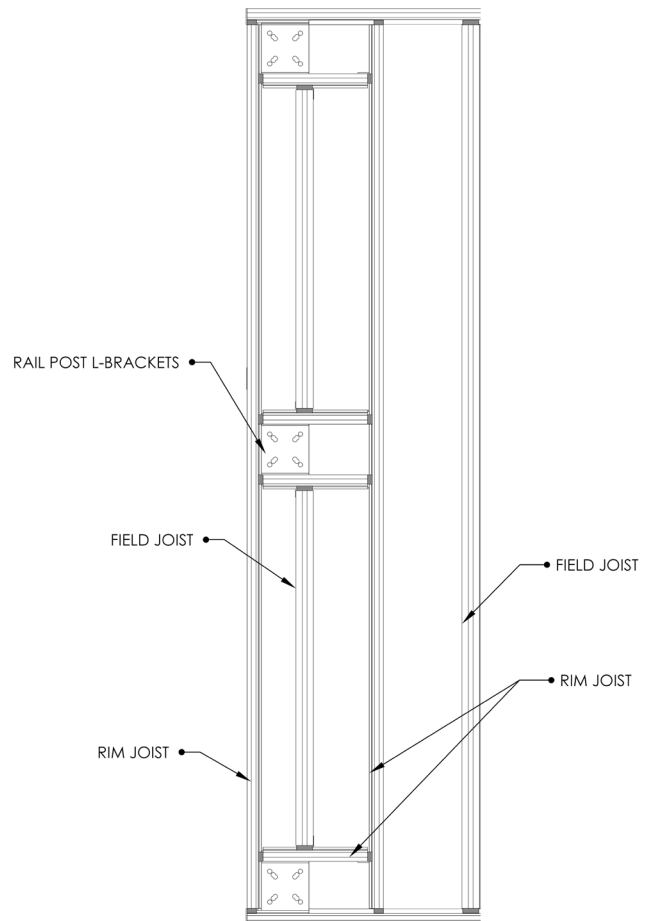
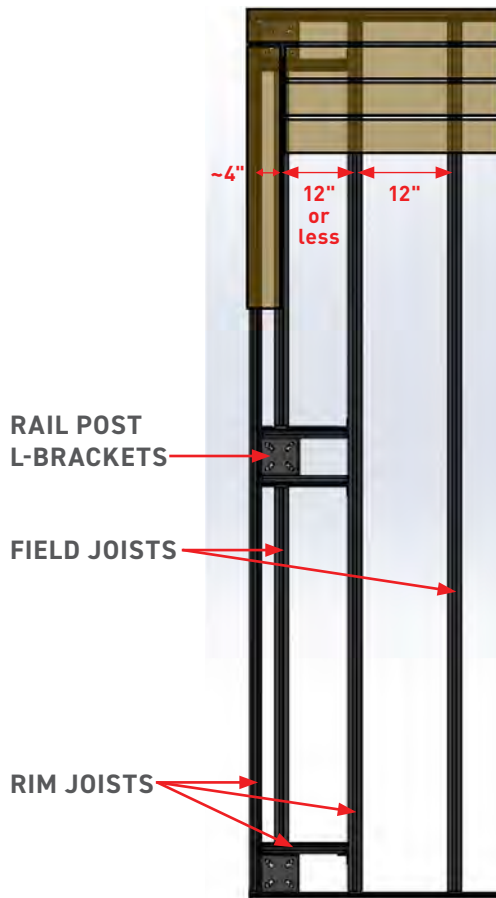

Additional Considerations (continued)

DOUBLE PICTURE FRAME

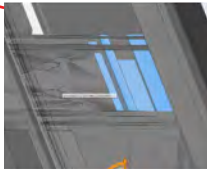
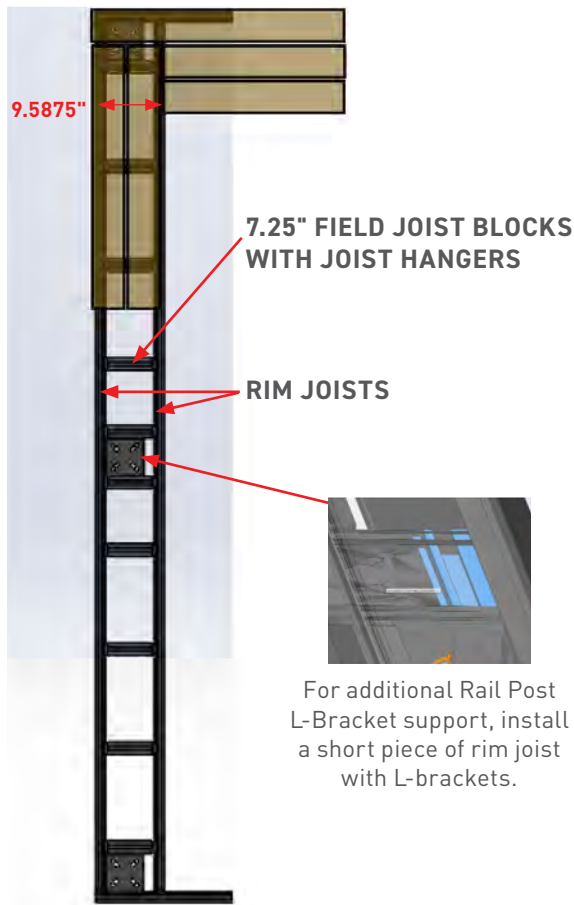

For additional Rail Post L-Bracket support, install a short piece of rim joist with L-brackets.

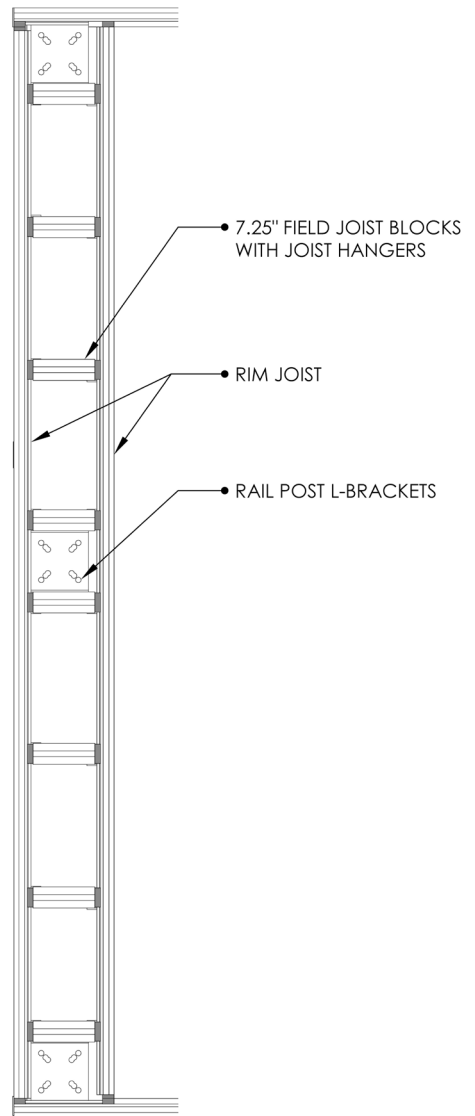

Additional Considerations

Alternate Joist Angle Bracket

Aside from 90-degree angle brackets, a 135-degree angle bracket or adjustable angle bracket may be used to install rim joists in non-rectangular frame design. A variety of complex deck shapes can be achieved using adjustable angle brackets.

When using angle brackets other than 90 degrees, adjustable angle brackets will be required to install field joists at the same angle.

90 DEGREE ANGLE BRACKET

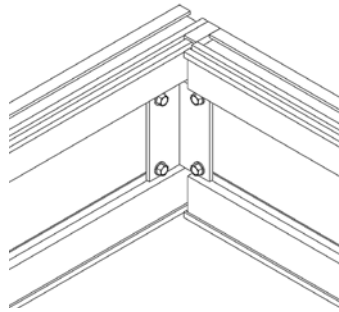

135 DEGREE ANGLE BRACKET

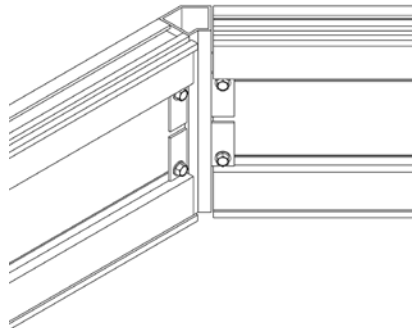

**ADJUSTABLE ANGLE BRACKET
(100 TO 180 DEGREES)**

